

AIRSTAGE

AIR CONDITIONER

Wall mounted type

FUJITSU

REFRIGERANT **R32**
INVERTER

DESIGN & TECHNICAL MANUAL

INDOOR



ASEG18KLCA
ASEG24KLCA

OUTDOOR



AOEG18KLCA



AOEG24KLCA

FUJITSU GENERAL LIMITED

DR_AS128ES_02
2023.12.18

Notices:

- Product specifications and design are subject to change without notice for future improvement.
- For further details, please check with our authorized dealer.

CONTENTS

Part 1. INDOOR UNIT	1
1. Specifications	2
2. Dimensions	4
2-1. Models: ASEG18KLCA and ASEG24KLCA.....	4
3. Wiring diagrams	6
3-1. Models: ASEG18KLCA and ASEG24KLCA.....	6
4. Capacity table	7
4-1. Cooling capacity.....	7
4-2. Heating capacity.....	8
5. Fan performance	9
5-1. Air velocity distributions.....	9
5-2. Airflow.....	11
6. Operation noise (sound pressure)	13
6-1. Noise level curve.....	13
6-2. Sound level check point.....	14
7. Safety devices	15
8. Remote controller	16
8-1. Wireless remote controller.....	16
9. Function settings	18
9-1. Function settings by using remote controller.....	18
9-2. Custom code setting for wireless remote controller.....	22
10. Accessories	23
10-1. Models: ASEG18KLCA and ASEG24KLCA.....	23

CONTENTS (continued)

Part 2. OUTDOOR UNIT	25
1. Specifications	26
2. Dimensions	27
2-1. Model: AOEG18KLCA	27
2-2. Model: AOEG24KLCA	28
3. Installation space	29
3-1. Models: AOEG18KLCA and AOEG24KLCA	29
4. Refrigerant circuit	32
4-1. Model: AOEG18KLCA	32
4-2. Model: AOEG24KLCA	33
5. Wiring diagrams	34
5-1. Model: AOEG18KLCA	34
5-2. Model: AOEG24KLCA	34
6. Capacity compensation rate for pipe length and height difference	35
6-1. Model: AOEG18KLCA	35
6-2. Model: AOEG24KLCA	36
7. Additional charge calculation	37
7-1. Model: AOEG18KLCA	37
7-2. Model: AOEG24KLCA	37
8. Airflow	38
8-1. Model: AOEG18KLCA	38
8-2. Model: AOEG24KLCA	38
9. Operation noise (sound pressure)	39
9-1. Noise level curve.....	39
9-2. Sound level check point	40
10. Electrical characteristics	41
11. Safety devices	42
12. Accessories	43
12-1.Models: AOEG18KLCA and AOEG24KLCA	43

Part 1. INDOOR UNIT

WALL MOUNTED TYPE:

ASEG18KLCA

ASEG24KLCA

1. Specifications

Type				Wall mounted		
				Inverter heat pump		
Model name				ASEG18KLCA	ASEG24KLCA	
Power supply				230 V ~ 50 Hz		
Available voltage range				198—264 V		
Capacity	Cooling	Rated	kW	5.20	7.10	
			Btu/h	17,700	24,200	
		Min.—Max.	kW	0.9—5.5	0.9—7.7	
	Heating	Rated	Btu/h	3,000—18,700	3,000—26,200	
			kW	6.30	8.00	
			Btu/h	21,400	27,200	
Min.—Max.		kW	0.6—7.6	0.9—9.0		
		Btu/h	2,000—25,900	3,000—30,700		
Input power	Cooling	Rated	kW	1.685	2.42	
				Min.—Max.	0.14—2.09	0.18—2.74
	Heating	Rated	kW	1.800	2.225	
				Min.—Max.	0.10—1.93	0.15—2.66
	Fan	HIGH	W	32	57	
				MED	25	34
				LOW	16	17
				QUIET	10	10
	Current	Cooling	Rated	A	7.5	10.9
					Heating	8.0
EER	Cooling		kW/kW	3.09	2.93	
COP	Heating		kW/kW	3.50	3.60	
Sensible capacity	Cooling		kW	3.93	4.92	
Power factor	Cooling		%	98.0		
	Heating		%	98.0		
Moisture removal			L/h (pints/h)	1.9 (3.3)	3.1 (5.5)	
Maximum operating current *1	Cooling		A	9.5	13.5	
	Heating		A	13.5	17.5	
Fan	Cooling	HIGH	m ³ /h	865	1,040	
				MED	780	880
				LOW	665	685
				QUIET	555	555
				QUIET	995	1,040
	Heating	HIGH	m ³ /h	810	810	
				MED	700	695
				LOW	590	585
				QUIET		
				QUIET		
Type × Q'ty				Crossflow fan × 1		
Motor output			W	61		
Sound pressure level *2	Cooling	HIGH	dB (A)	47	51	
				MED	44	45
				LOW	40	38
				QUIET	35	33
	Heating	HIGH	dB (A)	50	52	
				MED	45	45
				LOW	41	41
				QUIET	37	37
Heat exchanger type	Dimensions (H × W × D)	mm	Main: 384 × 630 × 20.0	Main: 384 × 630 × 20.0		
			Sub: 126 × 630 × 13.30	Sub1: 84 × 630 × 13.30		
	Fin pitch		Man: 1.1, Sub: 1.4	Man: 1.1, Sub1: 1.4, Sub2: 1.4		
	Rows × Stages		Main: 2 × 24, Sub: 1 × 6	Main: 2 × 24, Sub1: 1 × 4, Sub2: 1 × 6		
	Pipe type		Copper tube			
	Fin type		Aluminum			
Enclosure	Material		Polystyrene			
	Color		White Approximate color of Munsell N 9.25/			
Dimensions (H × W × D)	Net	mm	293 × 790 × 249			
	Gross	mm	320 × 840 × 375			
Weight	Net	kg	9.5	10.0		
	Gross	kg	12.0	12.5		
Connection pipe	Size	Liquid	mm (in)	Ø 6.35 (Ø 1/4)	Ø 6.35 (Ø 1/4)	
		Gas	mm (in)	Ø 9.52 (Ø 3/8)	Ø 12.70 (Ø 1/2)	
	Method			Flare		
Drain hose	Material		PP+HDPE			
	Tip diameter	mm	Ø 13.8 (I.D.), Ø 15.8 to Ø 16.7 (O.D.)			
Operation range	Cooling	°C	18 to 32			
		%RH	80 or less			
	Heating	°C	16 to 30			
Remote controller type			Wireless			

NOTES:

- Specifications are based on the following conditions:
 - Cooling: Indoor temperature of 27 °CDB/19 °CWB, and outdoor temperature of 35 °CDB/24 °CWB
 - Heating: Indoor temperature of 20 °CDB/15 °CWB, and outdoor temperature of 7 °CDB/6 °CWB
 - Pipe length: 5 m, Height difference: 0 m (Between outdoor unit and indoor unit)
- Protective function might work when using it outside the operation range.
- *1: Maximum current is maximum value when operated within the operation range.
- *2: Sound pressure level:
 - Measured values in manufacturer's anechoic chamber
 - Because of the surrounding sound environment, the sound levels measured in actual installation conditions might be higher than the specified values here.

Specifications for ErP Lot10					
Model name		ASEG18KLCA		ASEG24KLCA	
Energy efficiency class	Cooling	A ⁺⁺			
	Heating (Average)	A ⁺			
Pdesign	Cooling	kW	5.2 (35 °C)	7.1 (35 °C)	
	Heating (Average)		4.8 (-10 °C)	7.1 (-10 °C)	
SEER	Cooling	kWh/kWh	7.20	7.10	
SCOP	Heating (Average)		4.30	4.00	
Annual energy consumption	QCE	kWh/a	253	350	
	QHE (Average)		1,563	2,485	
Sound power level	Cooling	HIGH	dB (A)	60	64
	Heating			65	65

2. Dimensions

2-1. Models: ASEG18KLCA and ASEG24KLCA

Unit: mm

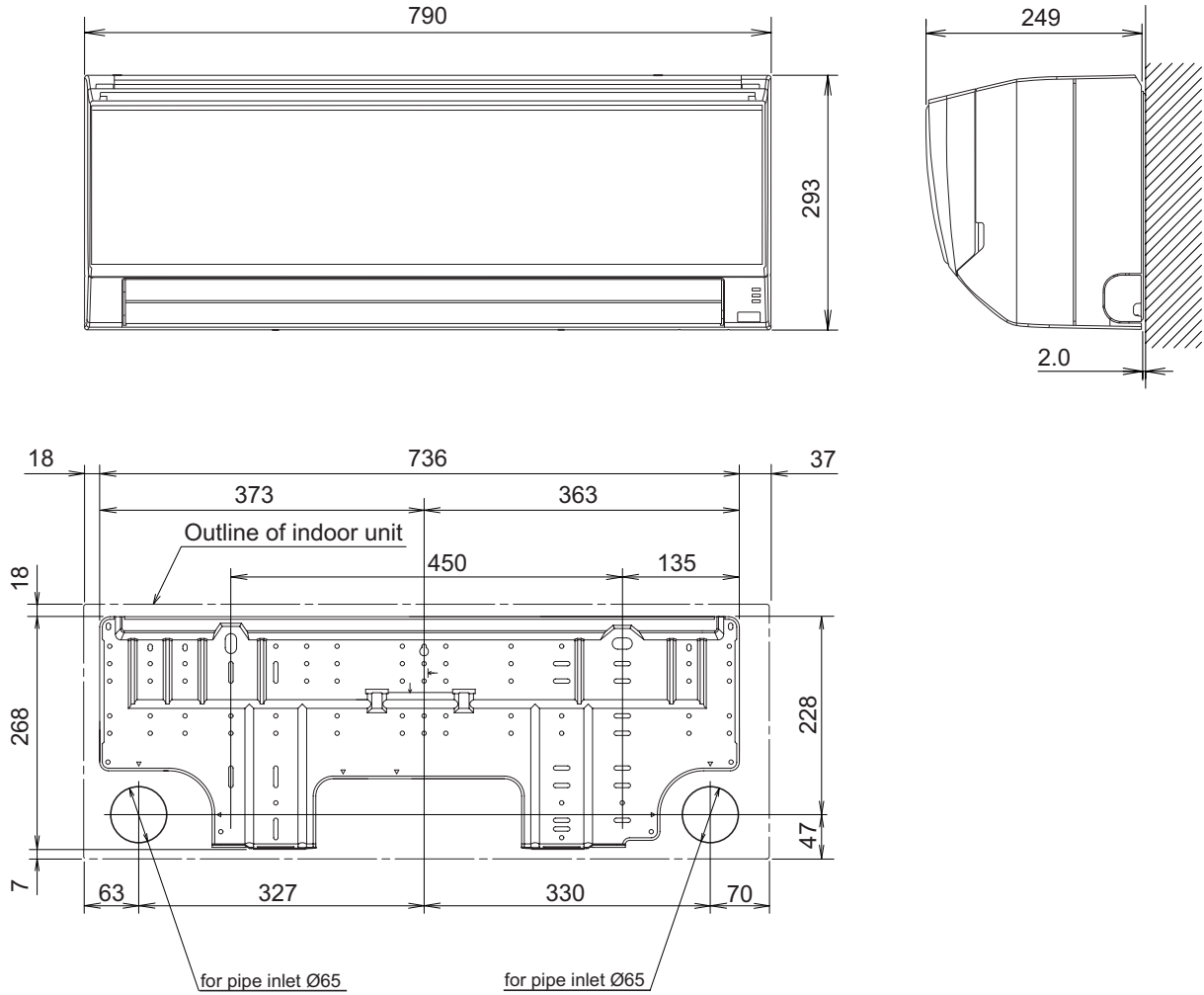

Installation space requirement

Provide sufficient installation space for product safety.

Unit: mm

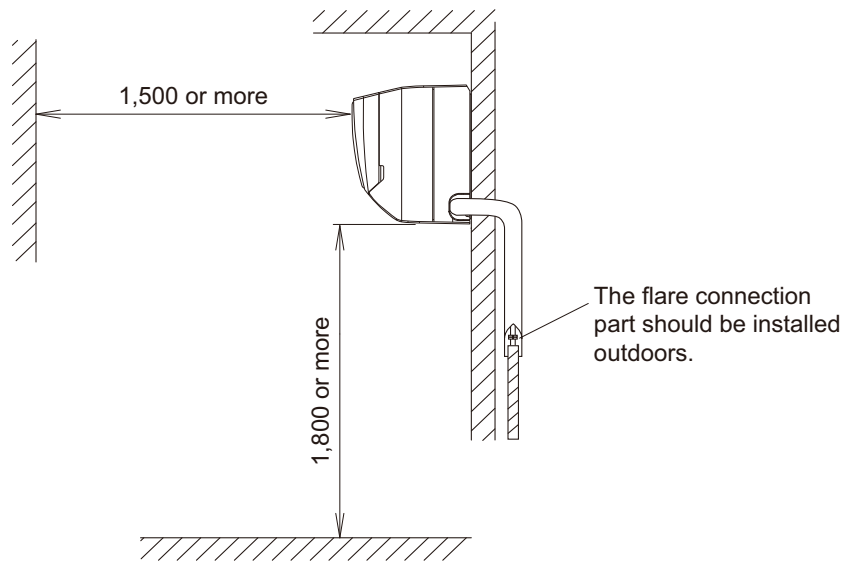
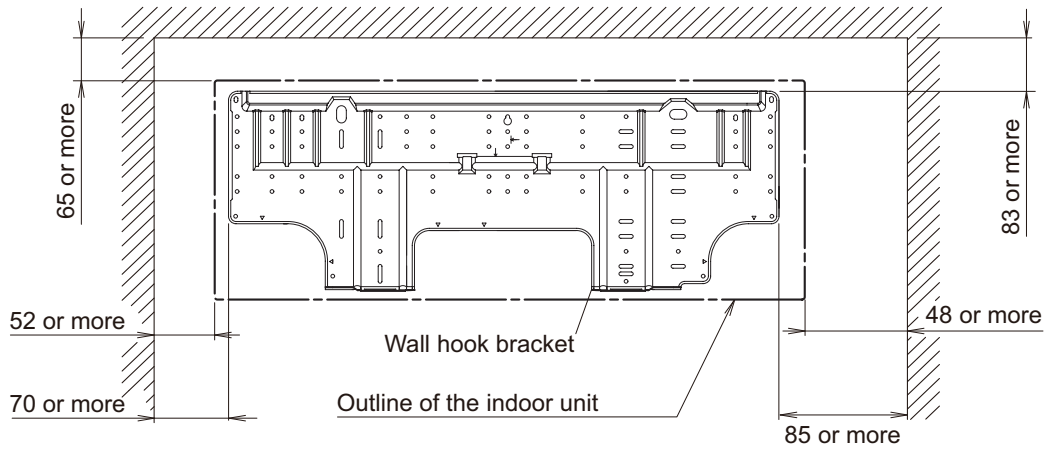

3. Wiring diagrams

3-1. Models: ASEG18KLCA and ASEG24KLCA

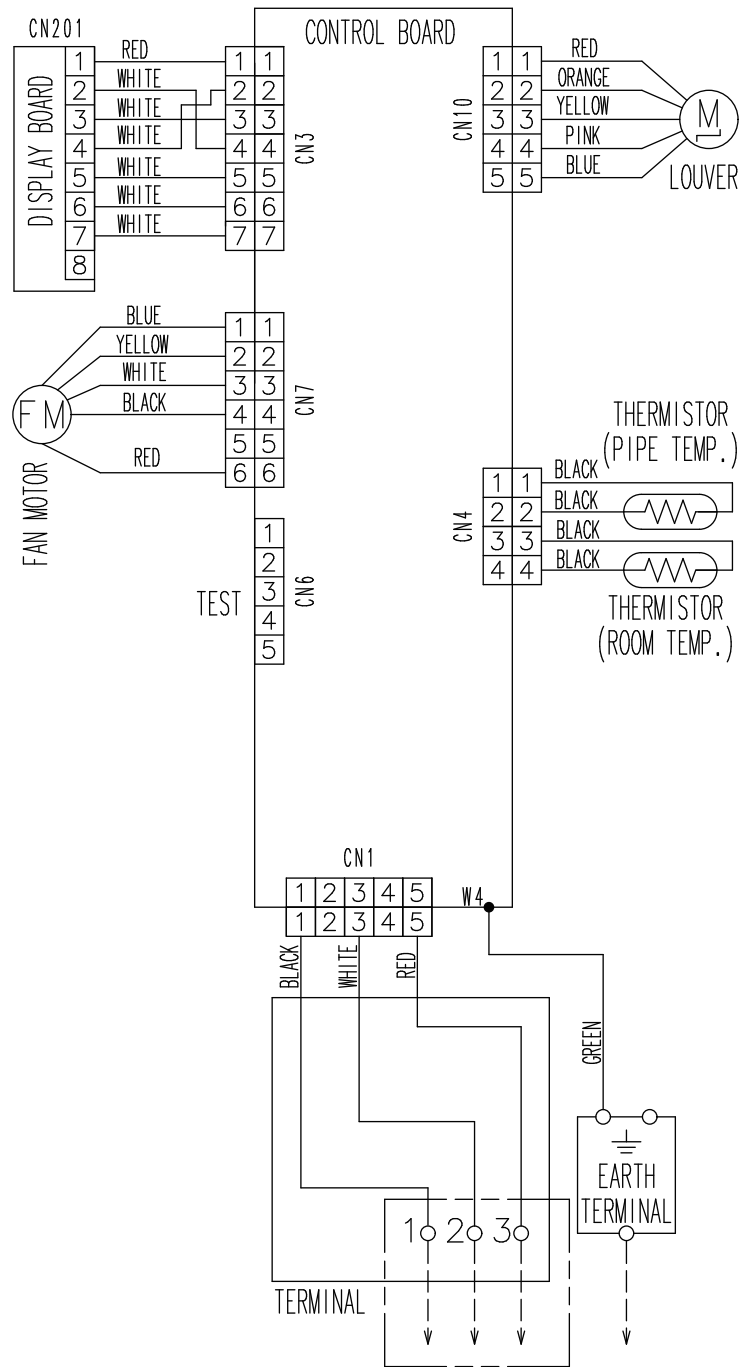

4. Capacity table

Capacity tables show each of following values calculated based on the outdoor temperature and the indoor temperature, under given Airflow Rate (AFR):

For cooling capacity: Total Capacity (TC), Sensible Heat Capacity (SHC), and Input Power (IP)

For heating capacity: Total Capacity (TC) and Input Power (IP)

4-1. Cooling capacity

■ Model: ASEG18KLCA

AFR		m ³ /h																		865	
Outdoor temperature	Indoor temperature																				
	18			21			23			25			27			29			32		
	°CDB			°CWB			°CDB			°CWB			°CDB			°CWB			°CDB		
	TC	SHC	IP	TC	SHC	IP	TC	SHC	IP	TC	SHC	IP	TC	SHC	IP	TC	SHC	IP	TC	SHC	IP
-10	3.20	2.79	1.99	3.51	3.05	2.01	3.61	3.15	2.03	3.84	3.35	2.05	3.96	3.45	2.07	4.22	3.68	2.09	4.50	3.92	2.11
-5	2.94	2.69	1.99	3.22	2.94	2.01	3.31	3.03	2.03	3.52	3.22	2.05	3.63	3.32	2.07	3.87	3.54	2.09	4.13	3.77	2.11
0	2.67	2.59	1.99	2.93	2.83	2.01	3.02	2.91	2.03	3.21	3.10	2.05	3.31	3.20	2.07	3.52	3.41	2.09	3.76	3.63	2.11
5	3.49	2.96	1.95	3.82	3.24	1.97	3.93	3.34	1.99	4.18	3.55	2.02	4.31	3.66	2.04	4.60	3.90	2.06	4.90	4.16	2.08
10	3.24	2.85	1.98	3.54	3.11	2.00	3.65	3.21	2.02	3.88	3.41	2.04	4.00	3.52	2.06	4.26	3.75	2.08	4.55	4.00	2.10
15	4.80	3.47	1.19	5.25	3.80	1.20	5.41	3.91	1.22	5.75	4.16	1.23	5.93	4.29	1.24	6.32	4.57	1.25	6.74	4.87	1.26
20	4.61	3.39	1.34	5.05	3.71	1.36	5.20	3.82	1.37	5.53	4.06	1.39	5.70	4.19	1.40	6.08	4.46	1.41	6.48	4.76	1.43
25	4.58	3.36	1.33	5.01	3.68	1.35	5.16	3.79	1.36	5.49	4.03	1.37	5.66	4.16	1.39	6.03	4.43	1.40	6.43	4.72	1.41
30	4.39	3.27	1.47	4.81	3.58	1.49	4.95	3.69	1.51	5.27	3.92	1.52	5.43	4.04	1.54	5.78	4.31	1.55	6.17	4.59	1.57
35	4.21	3.18	1.62	4.60	3.48	1.63	4.74	3.59	1.65	5.04	3.81	1.67	5.20	3.93	1.69	5.54	4.19	1.70	5.91	4.46	1.72
40	3.55	2.98	1.34	3.88	3.26	1.35	4.00	3.36	1.37	4.25	3.57	1.38	4.39	3.68	1.39	4.67	3.92	1.41	4.98	4.18	1.42
46	2.47	2.47	0.98	2.70	2.70	0.99	2.78	2.78	1.00	2.96	2.96	1.01	3.05	3.05	1.02	3.25	3.25	1.03	3.46	3.46	1.04

■ Model: ASEG24KLCA

AFR		m ³ /h																		1,040	
Outdoor temperature	Indoor temperature																				
	18			21			23			25			27			29			32		
	°CDB			°CWB			°CDB			°CWB			°CDB			°CWB			°CDB		
	TC	SHC	IP	TC	SHC	IP	TC	SHC	IP	TC	SHC	IP	TC	SHC	IP	TC	SHC	IP	TC	SHC	IP
-10	6.01	4.00	2.32	6.58	4.38	2.34	6.78	4.51	2.37	7.21	4.80	2.39	7.43	4.94	2.41	7.92	5.27	2.44	8.44	5.62	2.46
-5	5.57	3.82	2.48	6.10	4.18	2.50	6.29	4.30	2.53	6.69	4.58	2.55	6.89	4.72	2.58	7.34	5.03	2.61	7.83	5.36	2.63
0	5.14	3.64	2.64	5.62	3.98	2.66	5.79	4.10	2.69	6.16	4.36	2.72	6.35	4.49	2.75	6.77	4.79	2.77	7.21	5.11	2.80
5	5.96	4.02	2.31	6.53	4.40	2.34	6.73	4.54	2.36	7.15	4.83	2.38	7.37	4.97	2.41	7.86	5.30	2.43	8.38	5.65	2.46
10	5.63	3.95	2.46	6.16	4.32	2.48	6.35	4.45	2.51	6.75	4.73	2.53	6.96	4.88	2.56	7.42	5.20	2.59	7.91	5.54	2.61
15	6.65	4.40	1.61	7.27	4.81	1.62	7.50	4.96	1.64	7.97	5.27	1.66	8.22	5.43	1.67	8.76	5.79	1.69	9.33	6.17	1.71
20	6.45	4.29	1.81	7.06	4.69	1.83	7.28	4.83	1.85	7.74	5.14	1.87	7.98	5.30	1.89	8.50	5.65	1.90	9.06	6.02	1.92
25	6.31	4.23	1.92	6.91	4.62	1.94	7.12	4.76	1.96	7.57	5.07	1.98	7.81	5.22	2.00	8.32	5.57	2.02	8.87	5.93	2.04
30	6.03	4.10	2.12	6.60	4.49	2.14	6.80	4.63	2.17	7.23	4.92	2.19	7.45	5.07	2.21	7.94	5.40	2.23	8.47	5.76	2.25
35	5.74	3.98	2.32	6.28	4.36	2.35	6.48	4.49	2.37	6.89	4.77	2.40	7.10	4.92	2.42	7.57	5.24	2.44	8.07	5.59	2.47
40	5.33	3.85	2.09	5.84	4.21	2.11	6.02	4.34	2.14	6.40	4.61	2.16	6.59	4.75	2.18	7.03	5.07	2.20	7.49	5.40	2.22
46	3.98	3.31	1.59	4.35	3.62	1.61	4.49	3.73	1.63	4.77	3.97	1.64	4.92	4.09	1.66	5.24	4.36	1.68	5.59	4.65	1.69

4-2. Heating capacity

NOTE: Values mentioned in the table are calculated based on the maximum capacity.

Model: ASEG18KLCA

AFR	m ³ /h	995
-----	-------------------	-----

			Indoor temperature											
			16		18		20		22		24			
			TC	IP	TC	IP	TC	IP	TC	IP	TC	IP		
Outdoor temperature	°CDB	°CWB	kW		kW		kW		kW		kW			
	-15	-16	4.29	1.49	4.18	1.52	4.07	1.55	3.96	1.58	3.85	1.61		
	-10	-11	4.97	1.60	4.84	1.63	4.71	1.65	4.58	1.70	4.45	1.73		
	-5	-7	5.74	1.73	5.59	1.77	5.44	1.77	5.29	1.84	5.14	1.87		
	0	-2	6.67	1.88	6.49	1.92	6.32	1.93	6.14	2.00	5.97	2.04		
	5	3	7.41	2.01	7.21	2.05	7.02	2.09	6.83	2.13	6.63	2.17		
	7	6	8.09	2.09	7.88	2.13	7.67	2.18	7.46	2.22	7.25	2.26		
	10	8	8.47	2.17	8.25	2.21	8.03	2.24	7.81	2.31	7.59	2.35		
	15	10	8.46	2.00	8.24	2.04	8.02	2.09	7.80	2.12	7.57	2.16		
	20	15	7.85	1.56	7.64	1.59	7.44	1.63	7.23	1.66	7.03	1.69		
24	18	8.24	1.55	8.03	1.59	7.81	1.62	7.59	1.65	7.38	1.68			

Model: ASEG24KLCA

AFR	m ³ /h	1,040
-----	-------------------	-------

			Indoor temperature											
			16		18		20		22		24			
			TC	IP	TC	IP	TC	IP	TC	IP	TC	IP		
Outdoor temperature	°CDB	°CWB	kW		kW		kW		kW		kW			
	-15	-16	6.90	2.74	6.72	2.79	6.54	2.85	6.36	2.90	6.18	2.96		
	-10	-11	7.98	3.08	7.77	3.14	7.56	3.14	7.35	3.27	7.14	3.33		
	-5	-7	8.79	3.25	8.56	3.31	8.33	3.40	8.10	3.45	7.87	3.51		
	0	-2	9.20	3.16	8.96	3.22	8.72	3.31	8.48	3.35	8.24	3.42		
	5	3	9.53	2.89	9.28	2.95	9.03	3.01	8.78	3.07	8.53	3.13		
	7	6	9.50	2.55	9.25	2.60	9.00	2.66	8.75	2.71	8.50	2.76		
	10	8	9.54	2.45	9.29	2.50	9.04	2.59	8.79	2.60	8.54	2.65		
	15	10	9.60	2.24	9.35	2.29	9.10	2.38	8.84	2.38	8.59	2.43		
	20	15	9.66	2.04	9.41	2.08	9.16	2.17	8.90	2.16	8.65	2.20		
24	18	9.71	1.87	9.46	1.91	9.20	1.95	8.95	1.99	8.70	2.03			

5. Fan performance

5-1. Air velocity distributions

■ Model: ASEG18KLCA

Measuring conditions	Fan speed	Operation mode
	HIGH	FAN

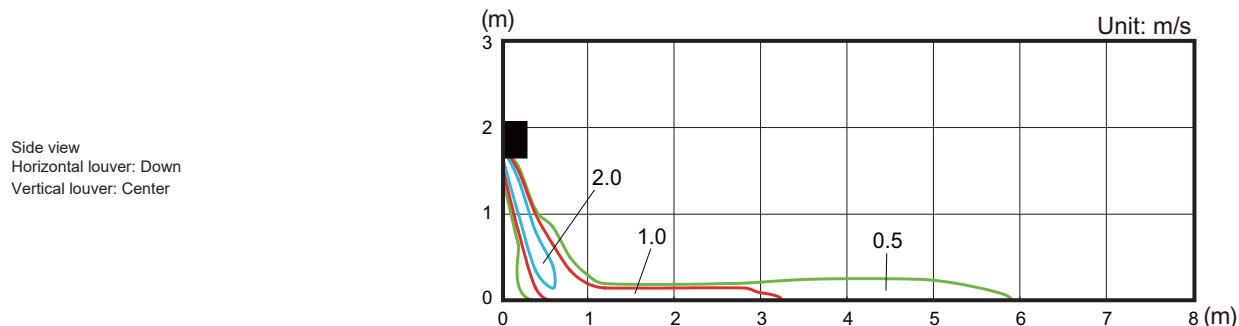
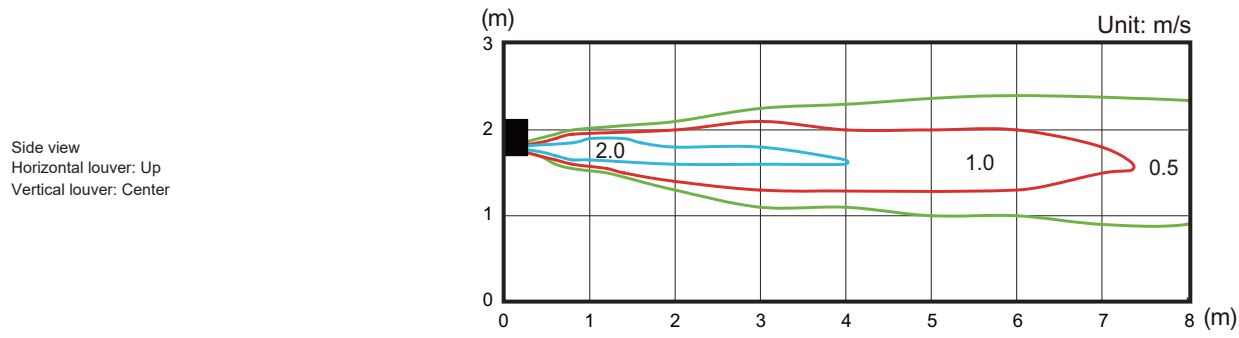
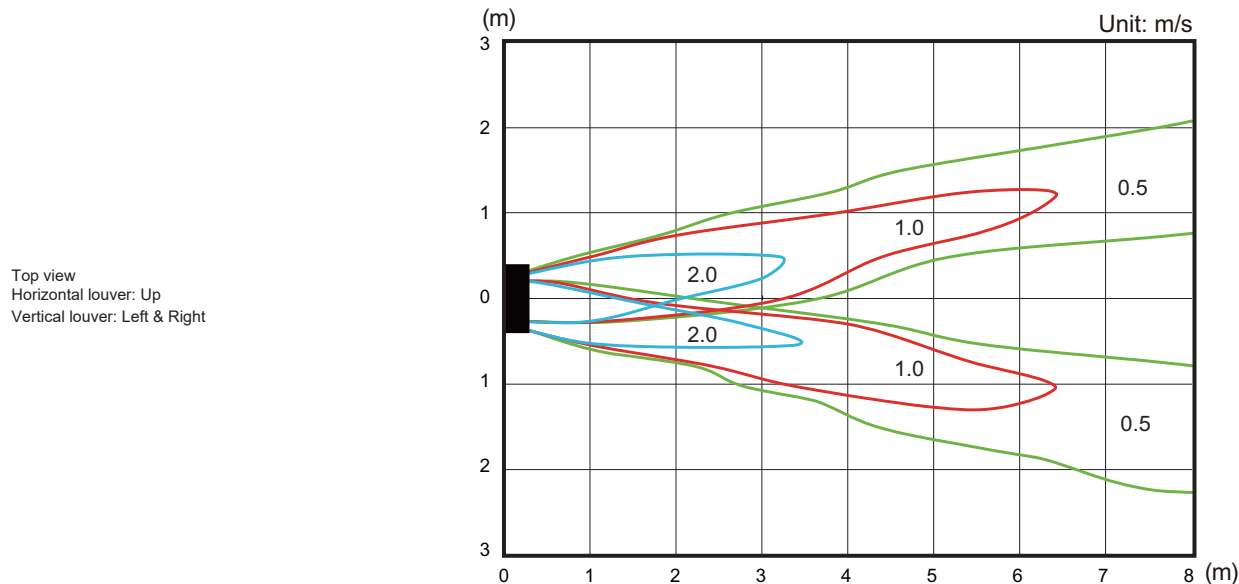
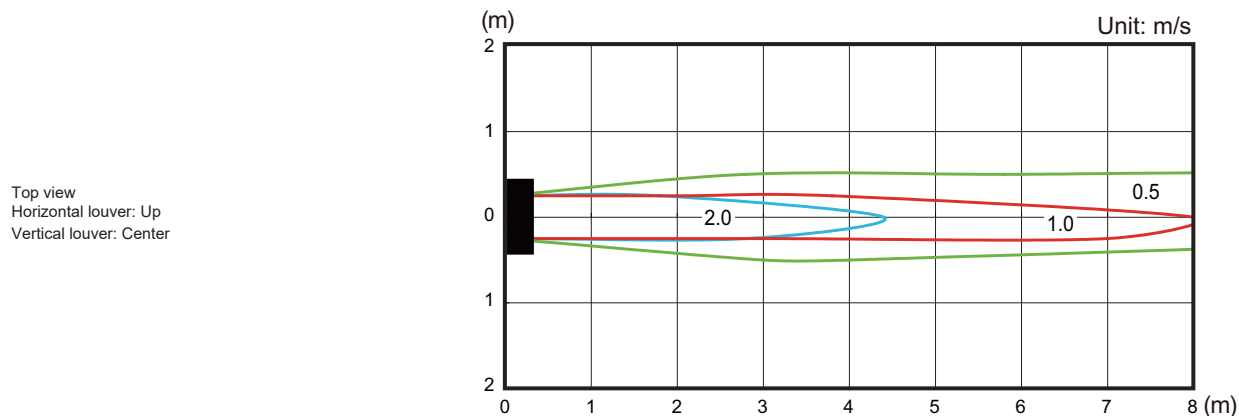

Model: ASEG24KLCA

Measuring conditions	Fan speed	Operation mode
	HIGH	FAN

Top view
Horizontal louver: Up
Vertical louver: Center

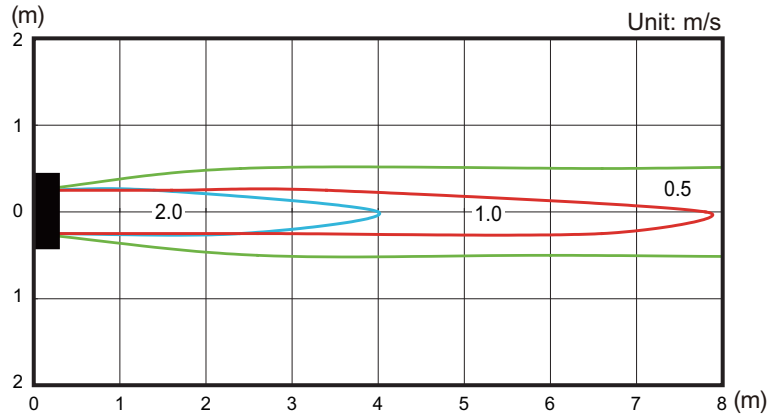

Top view
Horizontal louver: Up
Vertical louver: Left & Right

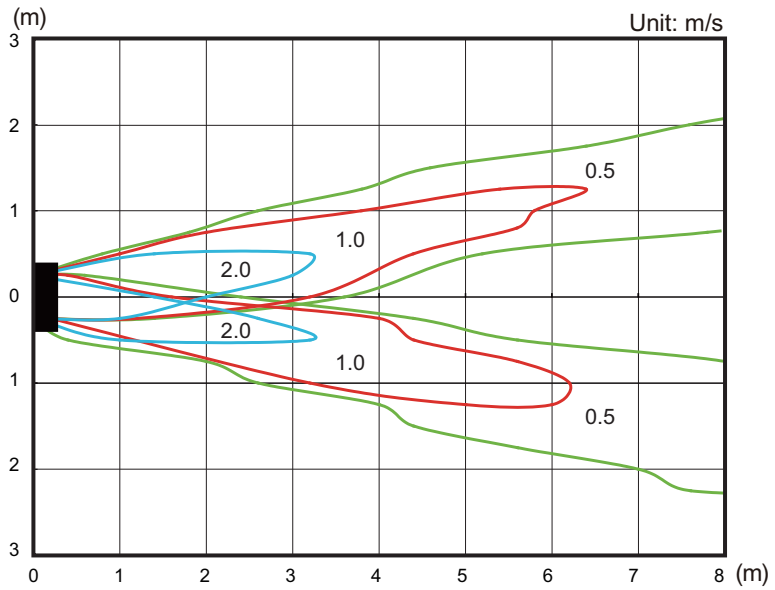

Side view
Horizontal louver: Up
Vertical louver: Center

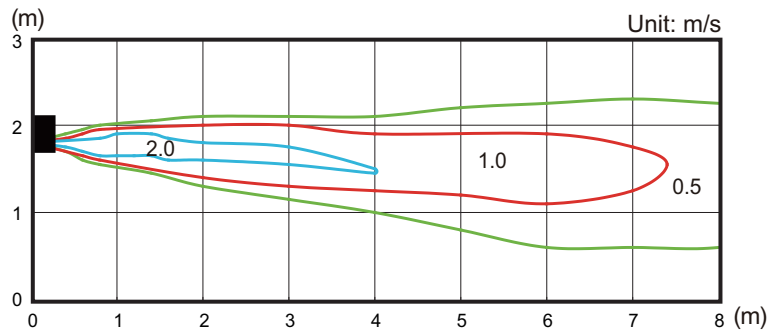

Side view
Horizontal louver: Down
Vertical louver: Center

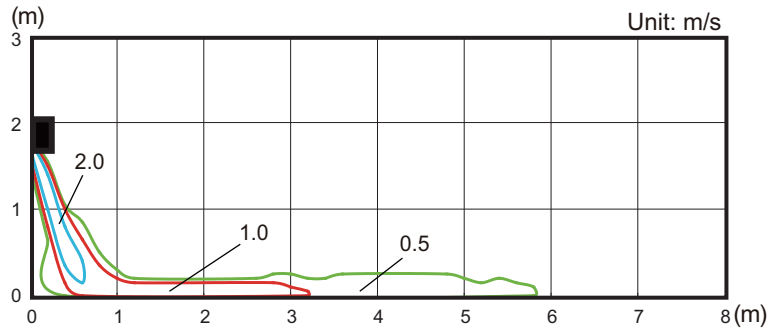

5-2. Airflow

■ Model: ASEG18KLCA

● Cooling

Fan speed	Airflow	
HIGH	m ³ /h	865
	l/s	240
	CFM	509
MED	m ³ /h	780
	l/s	217
	CFM	459
LOW	m ³ /h	665
	l/s	185
	CFM	391
QUIET	m ³ /h	555
	l/s	154
	CFM	327

● Heating

Fan speed	Airflow	
HIGH	m ³ /h	995
	l/s	276
	CFM	586
MED	m ³ /h	810
	l/s	225
	CFM	477
LOW	m ³ /h	700
	l/s	194
	CFM	412
QUIET	m ³ /h	590
	l/s	164
	CFM	347

■ Model: ASEG24KLCA

● Cooling

Fan speed	Airflow	
HIGH	m ³ /h	1,040
	l/s	289
	CFM	612
MED	m ³ /h	880
	l/s	244
	CFM	518
LOW	m ³ /h	685
	l/s	190
	CFM	403
QUIET	m ³ /h	555
	l/s	154
	CFM	327

● Heating

Fan speed	Airflow	
HIGH	m ³ /h	1,040
	l/s	289
	CFM	612
MED	m ³ /h	810
	l/s	225
	CFM	477
LOW	m ³ /h	695
	l/s	192
	CFM	406
QUIET	m ³ /h	585
	l/s	163
	CFM	344

6. Operation noise (sound pressure)

6-1. Noise level curve

Model: ASEG18KLCA

Cooling

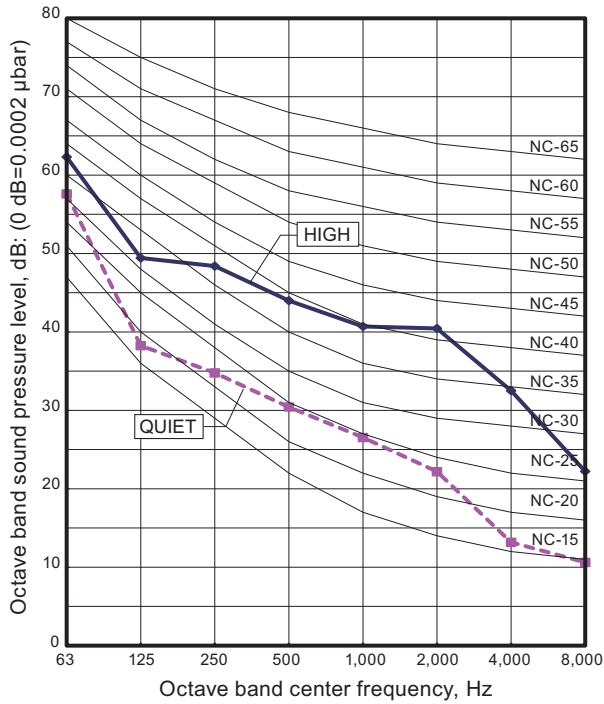

Heating

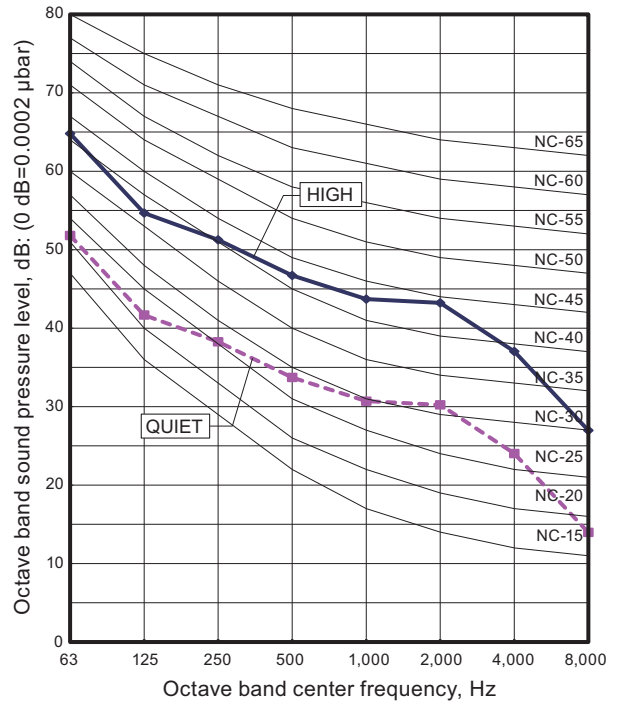

Model: ASEG24KLCA

Cooling

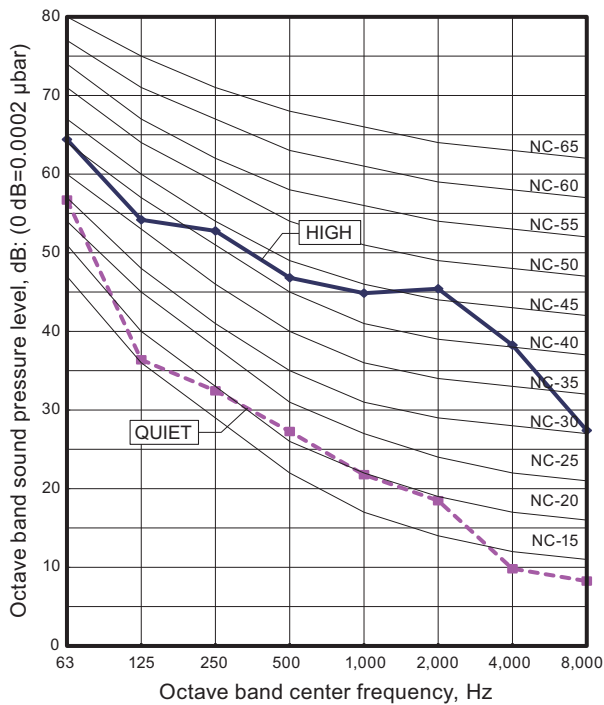

Heating

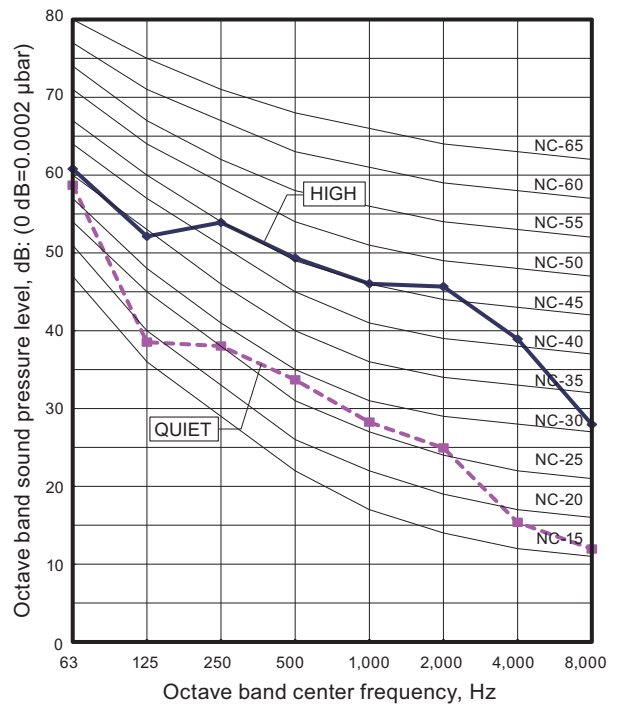

6-2. Sound level check point

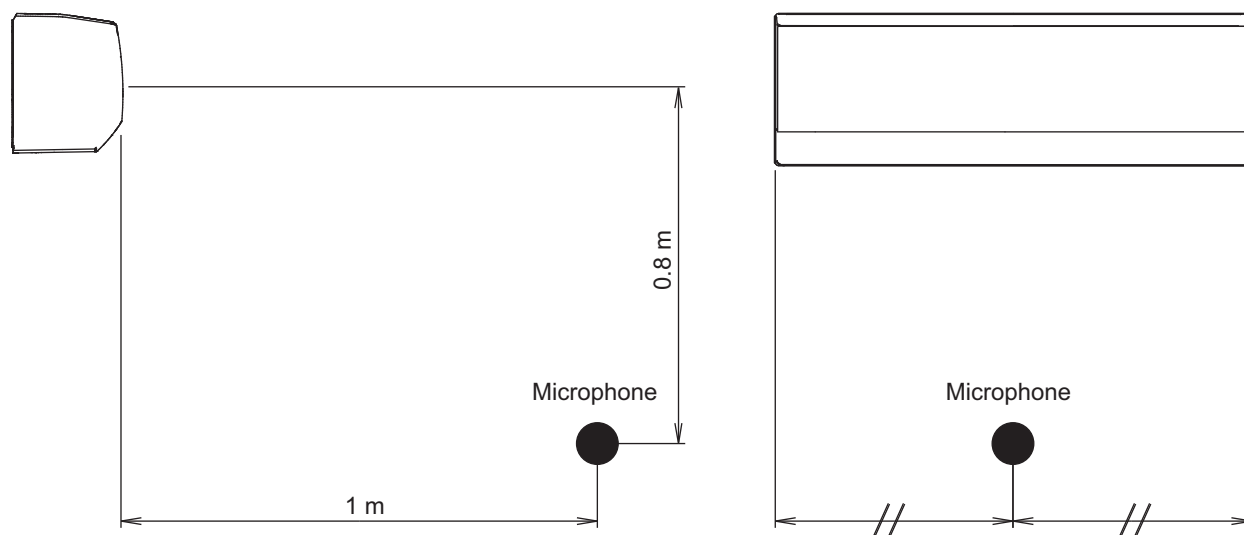

NOTE: Detailed shape of the actual indoor unit might be slightly different from the one illustrated above.

7. Safety devices

Type of protection	Protection form		Model	
			ASEG18KLCA	ASEG24KLCA
Circuit protection	Current fuse (PCB*)		250 V, 3.15 A	
Fan motor protection	Thermistor protection	Activate	150±15 °C Fan motor stop	
		Reset	120±15 °C Fan motor restart	

*PCB: Printed Circuit Board

8. Remote controller

8-1. Wireless remote controller

Overview

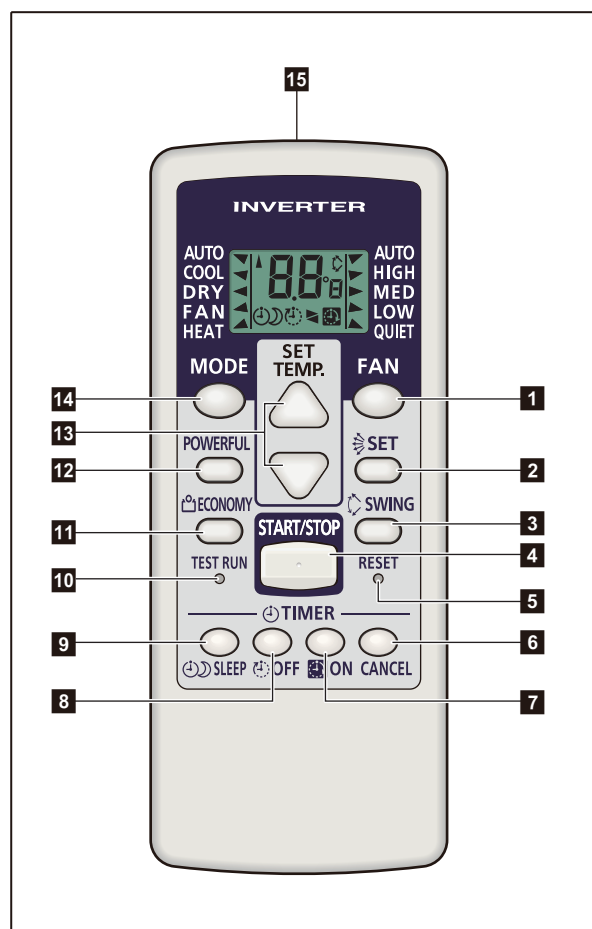

- 1 FAN button
- 2 SET button
- 3 SWING button
- 4 START/STOP button
- 5 RESET button
- 6 TIMER CANCEL button
- 7 ON TIMER button
- 8 OFF TIMER button
- 9 SLEEP TIMER button
- 10 TEST RUN button
 - Used only when installing the air conditioner, and should not be used under normal conditions, as it will cause the indoor unit's thermostat malfunction.
 - If this button is pressed during normal operation, the indoor unit will switch to test operation mode, and the operation indicator lamp and the timer indicator lamp on the indoor unit will begin to flash simultaneously.
 - To stop the test operation mode, press the START/STOP button. Then, the air conditioner stops the operation.

- 11 ECONOMY button
- 12 POWERFUL button
- 13 SET TEMP. (temperature) (▲ / ▼) button
 - Sets desired temperature.
 - Sets remote controller custom code.

- 14 MODE button
 - Switches operation mode (AUTO, COOL, DRY, FAN, and HEAT).
 - Starts/ends the remote controller custom code (max. 4 types) change.

- 15 Signal transmitter
- 16 Operating mode indicator
- 17 Signal transmit indicator
- 18 Temperature and time indicator
 - Displays set temperature.
 - In timer setting, it displays the timer time. After finishing the timer setting, set temperature will reappear.

- 19 Swing indicator
- 20 Fan speed indicator
- 21 Timer mode indicator

- Sleep timer
- OFF timer
- OFF-ON timer
- ON-OFF timer
- ON timer

Display panel

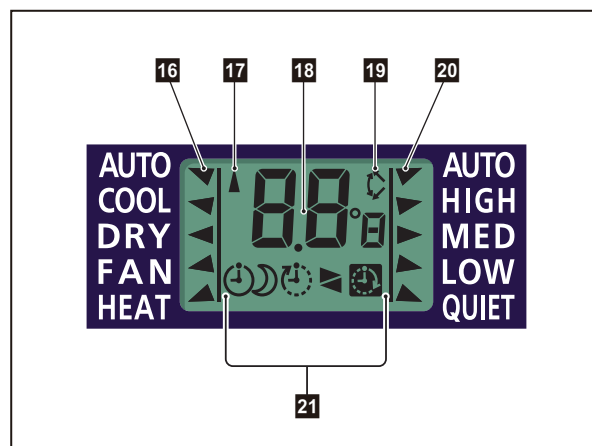

NOTE: Functions may differ by type of the indoor unit. For details, refer to the operation manual.

■ Specifications

● Controller

Unit: mm

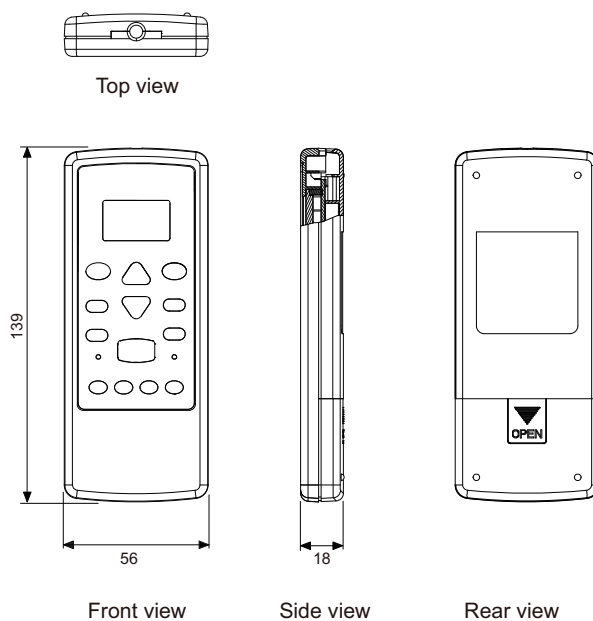

Size (H × W × D)	mm	139 × 56 × 18
Weight	g	70 (without batteries)

● Holder

Unit: mm

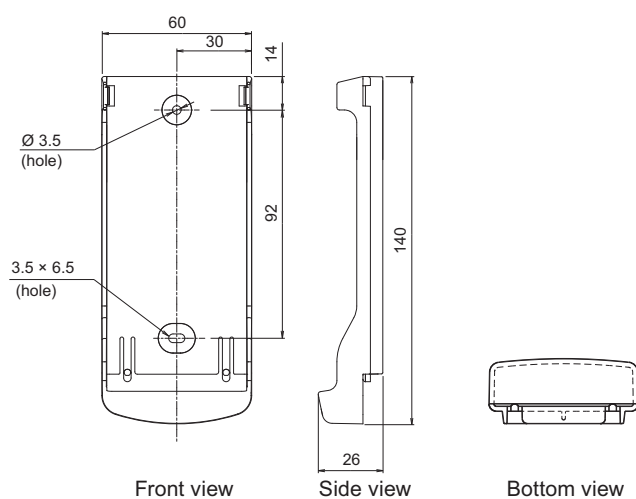

Size (H × W × D)	mm	140 × 60.4 × 26.2
Weight	g	25

9. Function settings

To adjust the functions of this product according to the installation environment, various types of function settings are available.

NOTE: Incorrect settings can cause a product malfunction.

9-1. Function settings by using remote controller

Some function settings can be changed on the remote controller. After confirming the setting procedure and the content of each function setting, select appropriate functions for your installation environment.

■ Setting procedure by using wireless remote controller

The function number and the associated setting value are displayed on the LCD of the remote controller. Follow the instructions written in the local setup procedure supplied with the remote controller, and select appropriate setting according to the installation environment.

Before connecting the power supply of the indoor unit, reconfirm following items:

- Piping air tightness test and vacuuming have been performed firmly.
- There is no wiring mistake.

Then, connect the power supply of indoor unit.

Entering function setting mode:

While pressing the FAN button and SET TEMP. (▲) button simultaneously, press the RESET button to enter the function setting mode.

STEP 1: Setting the remote controller custom code

Use the following steps to select the custom code of the remote controller. (Note that the air conditioner cannot receive a custom code if the air conditioner has not been set for the custom code.)

The custom codes that are set through this process are applicable only to the signal in the function setting.

For details on how to set the custom codes through the normal process, refer to ["Custom code setting for wireless remote controller"](#) on page 22.

1. Press the SET TEMP. (▲) (▼) buttons to change the custom code between $\text{A} \rightarrow \text{b} \rightarrow \text{c} \rightarrow \text{d}$. Match the code on the display to the air conditioner custom code. (Initially set to A .) If the custom code does not need to be selected, press the MODE button, and proceed to **STEP 2**.
2. Press the MODE button to accept the custom code, and proceed to **STEP 2**.

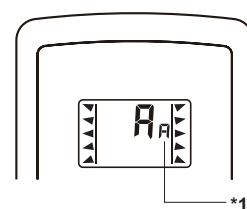

***1:** Small A is displayed on the right of the custom code during the function setting.

NOTES:

- The air conditioner custom code is set to A prior to shipment. To change the custom code, contact your retailer.
- The remote controller resets to custom code A when the batteries on the remote controller are replaced. If you use a custom code other than code A , reset the custom code after replacing the batteries.
- If you do not know the air conditioner custom code setting, try each of the custom codes ($\text{A} \rightarrow \text{b} \rightarrow \text{c} \rightarrow \text{d}$) until you find the code that operates the air conditioner.

STEP 2: Selecting the function number and setting value

1. Press the SET TEMP. (▲) (▼) buttons to select the function number. To switch between the left and right digits, press the MODE button.
2. Press the FAN button to proceed the setting value. To return the function number selection, press the FAN button again.
3. Press the SET TEMP. (▲) (▼) buttons to select the setting value. To switch between the left and right digits, press the MODE button.
4. Press the SLEEP button, then after you hear the beep emitted from the indoor unit, the START/STOP button in the order to confirm the settings.
5. Press the RESET button to cancel the function setting mode.
6. After completing the function setting, be sure to disconnect the power supply and then reconnect it.

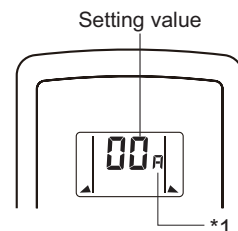
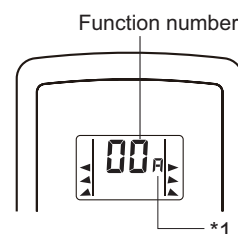

*1: Small  is displayed on the right of the custom code during the function setting.

 CAUTION

After disconnect the power supply, wait 30 seconds or more before reconnecting it. The function setting will not become active unless the power supply is disconnected and then reconnected.

■ Contents of function setting

Each function setting listed in this section is adjustable in accordance with the installation environment.

NOTE: Setting will not be changed if invalid numbers or setting values are selected.

● Function setting list

	Function no.	Functions
1)	11	Filter sign
2)	30/31	Room temperature control for indoor unit sensor
3)	40	Auto restart
4)	44	Remote controller custom code
5)	49	Indoor unit fan control for energy saving for cooling

1) Filter sign

Select appropriate intervals for displaying the filter sign on the indoor unit according to the estimated amount of dust in the air of the room.

If the indication is not required, select "No indication" (03).

Function number	Setting value	Setting description	Factory setting
11	00	Standard (400 hours)	
	01	Long interval (1,000 hours)	
	02	Short interval (200 hours)	
	03	No indication	◆

2) Room temperature control for indoor unit sensor

Depending on the installed environment, correction of the room temperature sensor may be required. Select the appropriate control setting according to the installed environment.

The temperature correction values show the difference from the Standard setting "00" (manufacturer's recommended value).

Function number	Setting value	Setting description	Factory setting		
30 (For cooling)	31 (For heating)	00	Standard setting	◆	
		01	No correction 0.0 °C		
		02	-0.5 °C	More cooling Less heating	
		03	-1.0 °C		
		04	-1.5 °C		
		05	-2.0 °C		
		06	-2.5 °C		
		07	-3.0 °C		
		08	-3.5 °C		
		09	-4.0 °C		
		10	+0.5 °C	Less cooling More heating	
		11	+1.0 °C		
		12	+1.5 °C		
		13	+2.0 °C		
		14	+2.5 °C		
		15	+3.0 °C		
		16	+3.5 °C		
17	+4.0 °C				

3) Auto restart

Enables or disables automatic restart after a power interruption.

Function number	Setting value	Setting description	Factory setting
40	00	Enable	◆
	01	Disable	

NOTE: Auto restart is an emergency function such as for power outage etc. Do not attempt to use this function in normal operation. Be sure to operate the unit by remote controller or external device.

4) Remote controller custom code

(Only for wireless remote controller)

The indoor unit custom code can be changed. Select the appropriate custom code.

Function number	Setting value	Setting description	Factory setting
44	00	A	◆
	01	B	
	02	C	
	03	D	

5) Indoor unit fan control for energy saving for cooling

Enables or disables the power-saving function by controlling the indoor unit fan rotation when the outdoor unit is stopped during cooling operation.

Function number	Setting value	Setting description	Factory setting
49	00	Disable	
	01	Enable	◆

00: When the outdoor unit is stopped, the indoor unit fan operates continuously following the setting on the remote controller.

01: When the outdoor unit is stopped, the indoor unit fan operates intermittently at a very low speed.

9-2. Custom code setting for wireless remote controller

To interconnect the air conditioner and the wireless remote controller, assignment of the custom code for the wireless remote controller is required.

NOTE: Air conditioner cannot receive a custom code if the air conditioner has not been set for the custom code.

1. Press the MODE button for at least 5 seconds to display the current custom code. (Initially set to \overline{A} .)

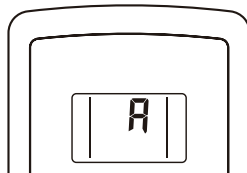







2. Press the SET TEMP. (\blacktriangle or \blacktriangledown) button to change the custom code between $\overline{A} \rightarrow \overline{b} \rightarrow \overline{c} \rightarrow \overline{d}$. Match the code on the display to the air conditioner custom code.
3. Press the MODE button again. The custom code will be changed.

NOTES:

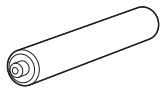
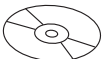
- If no button is pressed within 30 seconds after the custom code is displayed, the system returns to the original clock indicator. In this case, start again from step 1.
- The air conditioner custom code is set to \overline{A} prior to shipment. To change the custom code, contact your retailer.
- The remote controller resets to custom code \overline{A} when the batteries in the remote controller are replaced. If you use a custom code other than code \overline{A} , reset the appropriate custom code after replacing the batteries. If you do not know the assigned code for the air conditioner, try each of the custom code ($\overline{A} \rightarrow \overline{b} \rightarrow \overline{c} \rightarrow \overline{d}$) until you find the code which operates the air conditioner.

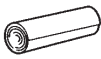
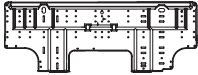
10. Accessories

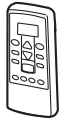
10-1. Models: ASEG18KLCA and ASEG24KLCA

Part name	Exterior	Q'ty	Part name	Exterior	Q'ty
Operating manual		1	Battery		2
Operating manual (CD-ROM)		1	Remote controller holder		1
Installation manual		1	Cloth tape		1
Wall hook bracket		1	Tapping screw (large)		5
Remote controller		1	Tapping screw (small)		2

Part 2. OUTDOOR UNIT

SINGLE TYPE:

AOEG18KLCA

AOEG24KLCA

1. Specifications

Type				Inverter heat pump				
Model name				AOEG18KLCA		AOEG24KLCA		
Power supply				230 V ~ 50 Hz				
Available voltage range				198—264 V				
Starting current				A		8.0		
Fan	Airflow rate	Cooling	m ³ /h	1,830		2,885		
		Heating		2,265		3,030		
	Type × Q'ty	Propeller fan × 1						
Motor output				W		23		
Sound pressure level *1	Cooling	Heating	dB (A)	50		55		
				56		57		
Sound power level	Cooling	Heating	dB (A)	61		65		
				66		67		
Heat exchanger type	Dimensions (H × W × D)		mm	Main1: 504 × 881 × 18.19		Main1: 588 × 881 × 18.19		
	Fin pitch			1.3				
	Rows × Stages		2 × 24		Main1: 1 × 28		Main2: 1 × 28	
	Pipe type		Copper					
	Fin type	Type (Material)		Aluminum				
Surface treatment		PC fin						
Compressor	Type × Q'ty		Twin rotary × 1					
	Motor output		W		900		1,060	
Refrigerant	Type (Global warming potential)		R32 (675)					
	Charge		g		850		1,100	
Refrigerant oil	Type		FW68S		RmM68AF			
	Amount		cm ³		350		400	
Enclosure	Material		Steel sheet					
	Color		Beige Approximate color of Munsell 10YR 7.5/1.0					
Dimensions (H × W × D)	Net		mm	542 × 799 × 290		632 × 799 × 290		
	Gross			602 × 940 × 375		692 × 940 × 375		
Weight	Net		kg	33		38		
	Gross			37		42		
Connection pipe	Size	Liquid	mm (in)	Ø 6.35 (Ø 1/4)		Ø 12.70 (Ø 1/2)		
		Gas		Ø 9.52 (Ø 3/8)				
	Method		Flare					
	Pre-charge length		m	15				
	Max. length			25		30		
Max. height difference		20		25				
Operation range	Cooling	Heating	°C	-10 to 46				
				-15 to 24				
Drain pipe	Material		PP+HDPE					
	Tip diameter		mm		Ø 13.0 (I. D.), Ø 16.0 to Ø 16.8 (O. D.)			
NOTES: <ul style="list-style-type: none"> Specifications are based on the following conditions: <ul style="list-style-type: none"> Cooling: Indoor temperature of 27 °CDB/19 °CWB, and outdoor temperature of 35 °CDB/24 °CWB Heating: Indoor temperature of 20 °CDB/15 °CWB, and outdoor temperature of 7 °CDB/6 °CWB Pipe length: 5 m, Height difference: 0 m (Between outdoor unit and indoor unit) Protective function might work when using it outside the operation range. *1: Sound pressure level <ul style="list-style-type: none"> Measured values in manufacturer's anechoic chamber Because of the surrounding sound environment, the sound levels measured in actual installation conditions might be higher than the specified values here. 								

2. Dimensions

2-1. Model: AOEG18KLCA

Unit: mm

OUTDOOR UNIT
AOEG18-24KLCA

OUTDOOR UNIT
AOEG18-24KLCA

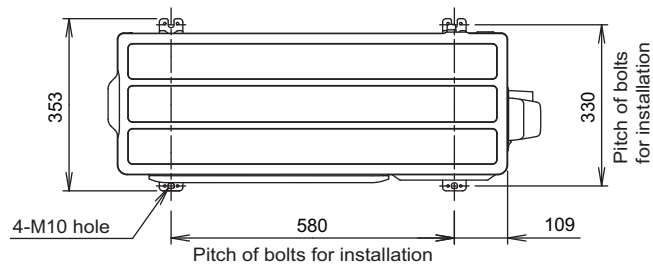

Top view

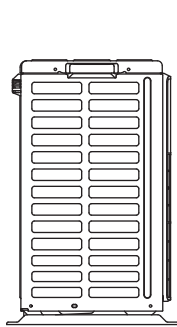

Side view

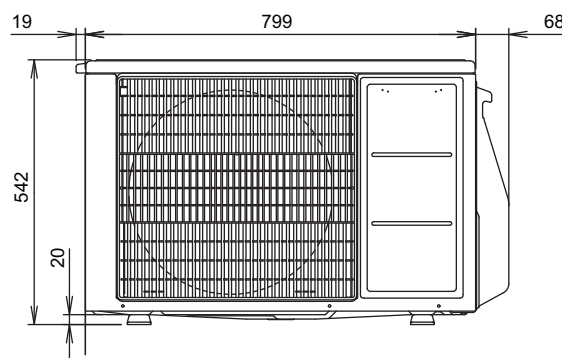

Front view

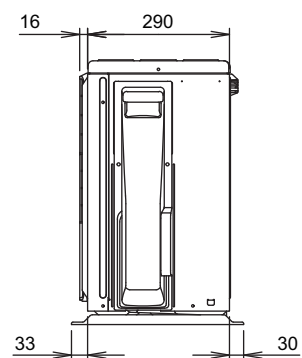

Side view

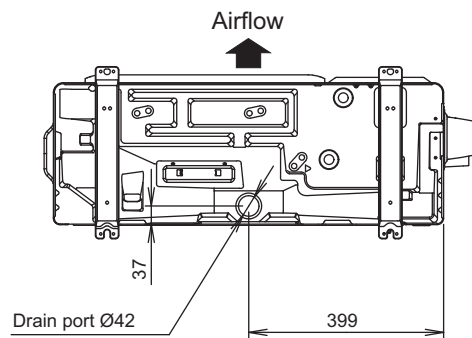

Bottom view

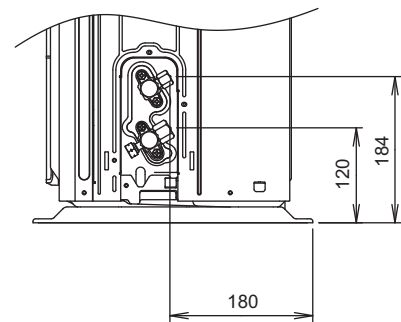

Side view (Valve part)

2-2. Model: AOEG24KLCA

Unit: mm

OUTDOOR UNIT
AOEG18-24KLCA

OUTDOOR UNIT
AOEG18-24KLCA

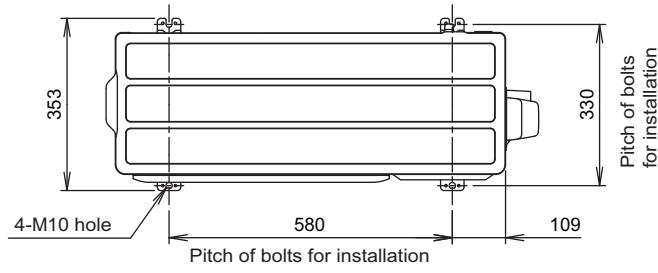

Top view

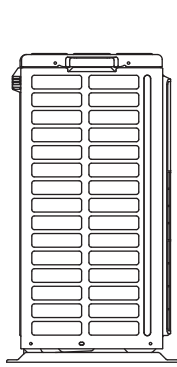

Side view

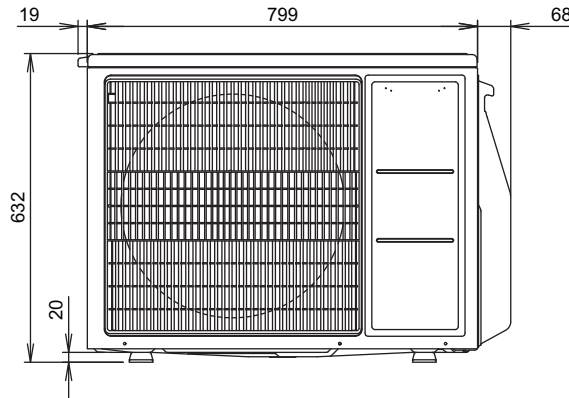

Front view

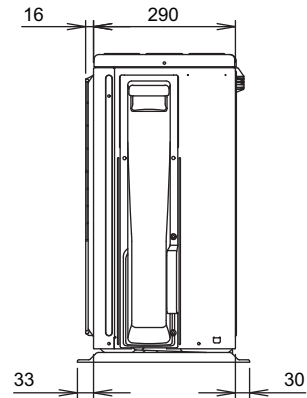

Side view

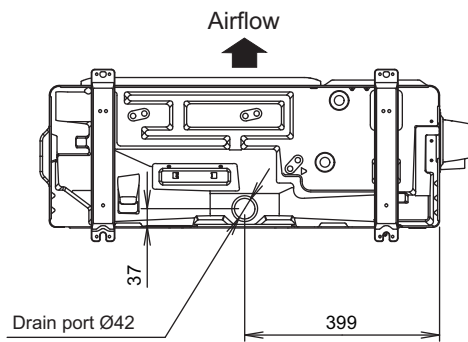

Bottom view

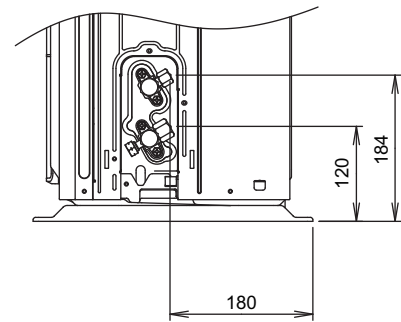

Side view (Valve part)

3. Installation space

3-1. Models: AOEG18KLCA and AOEG24KLCA

■ Space requirement

Provide sufficient installation space for product safety.

⚠ CAUTION

Keep the space shown in the installation examples.

If the installation is not performed accordingly, it could cause a short circuit and result in a lack of operating performance.

● Single outdoor unit installation

- When the upper space is open:

Unit: mm

Obstacles at rear only

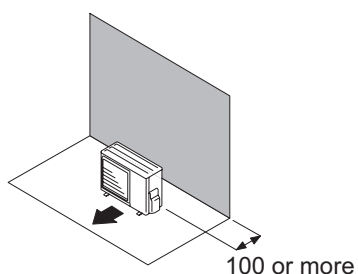

Obstacles at rear and sides

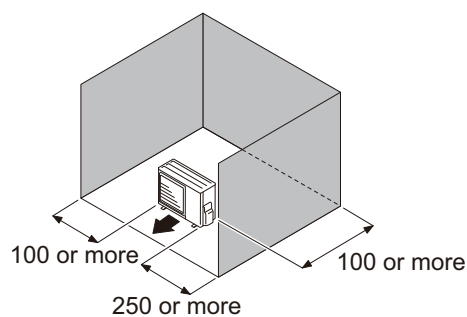

Obstacles at front

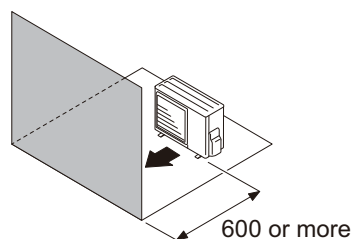

Obstacles at front and rear

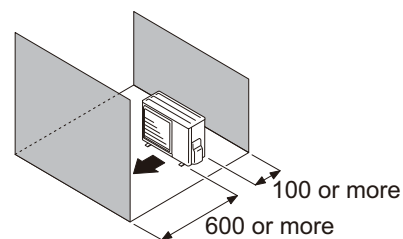

- When an obstruction in the upper space:

Unit: mm

Obstacles at rear and above

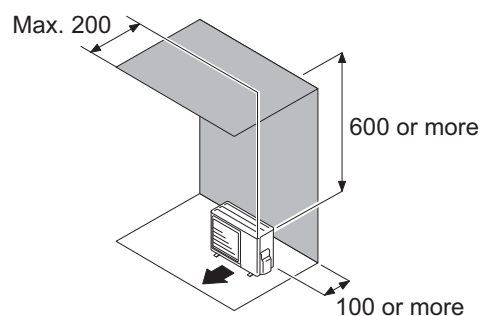

Obstacles at rear, sides, and above

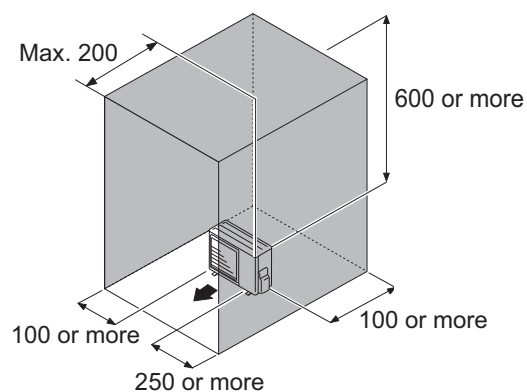

● Multiple outdoor unit installation

- Provide at least 250 mm of space between the outdoor units if multiple units are installed.
- When routing the piping from the side of an outdoor unit, provide space for piping.
- No more than 3 units must be installed side by side.
When 3 units or more are arranged in a line, provide the space as shown in the following example **“When an obstruction in the upper space:”**.

- **When the upper space is open:**

Unit: mm

Obstacles at rear only

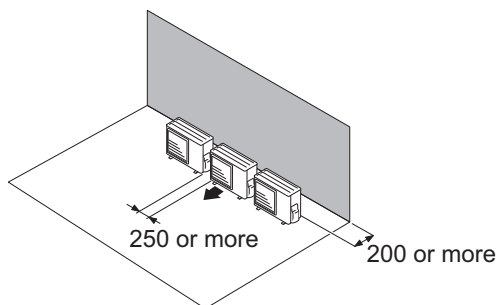

Obstacles at front only

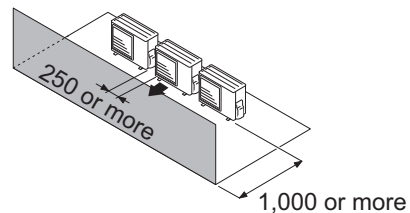

Obstacles at front and rear

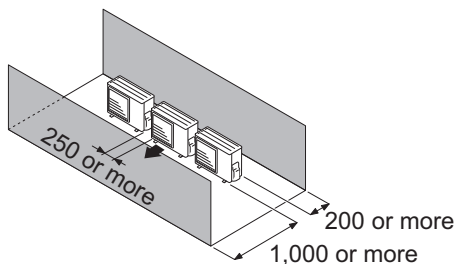

- **When an obstruction in the upper space:**

Unit: mm

Obstacles at rear and above.

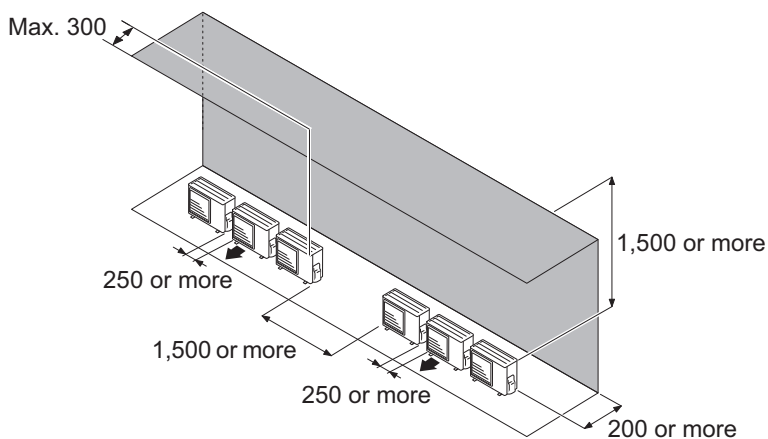

● Outdoor units installation in multi-row

Unit: mm

Single parallel unit arrangement

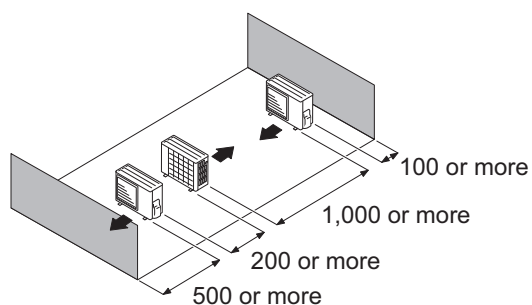

Multiple parallel unit arrangement

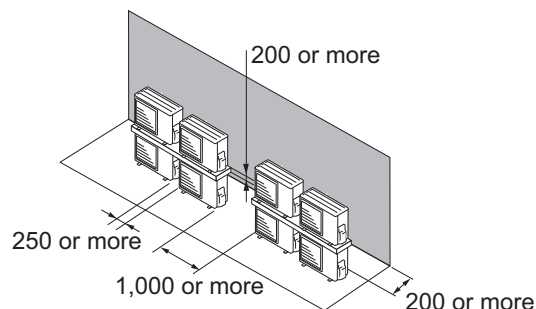
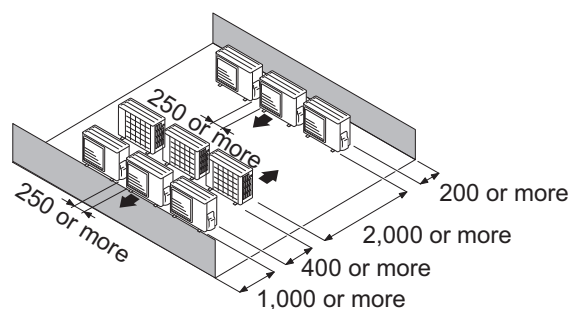

NOTES:

- If the space is larger than stated above, the condition will be the same as when there is no obstacle.
- When installing the outdoor unit, be sure to open the front and left side to obtain better operation efficiency.

⚠ CAUTION

- Do not install the outdoor unit in two-stage where the drain water could freeze. Otherwise the drainage from the upper unit may form ice and cause a malfunction of the lower unit.
- When the outdoor temperature is 0 °C or less, do not use the accessory drain pipe and drain cap. If the drain pipe and drain cap are used, the drain water in the pipe may freeze in extremely cold climate. (For reverse cycle model only.)
- In area with heavy snowfall, if the inlet and outlet of the outdoor unit is blocked with snow, it might become difficult to get warm, and it is likely to cause product malfunction. Construct a canopy and a pedestal, or place the unit on a high stand that is locally installed.

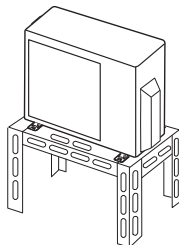

4. Refrigerant circuit

4-1. Model: AOEG18KLCA

OUTDOOR UNIT
AOEG18-24KLCA

OUTDOOR UNIT
AOEG18-24KLCA

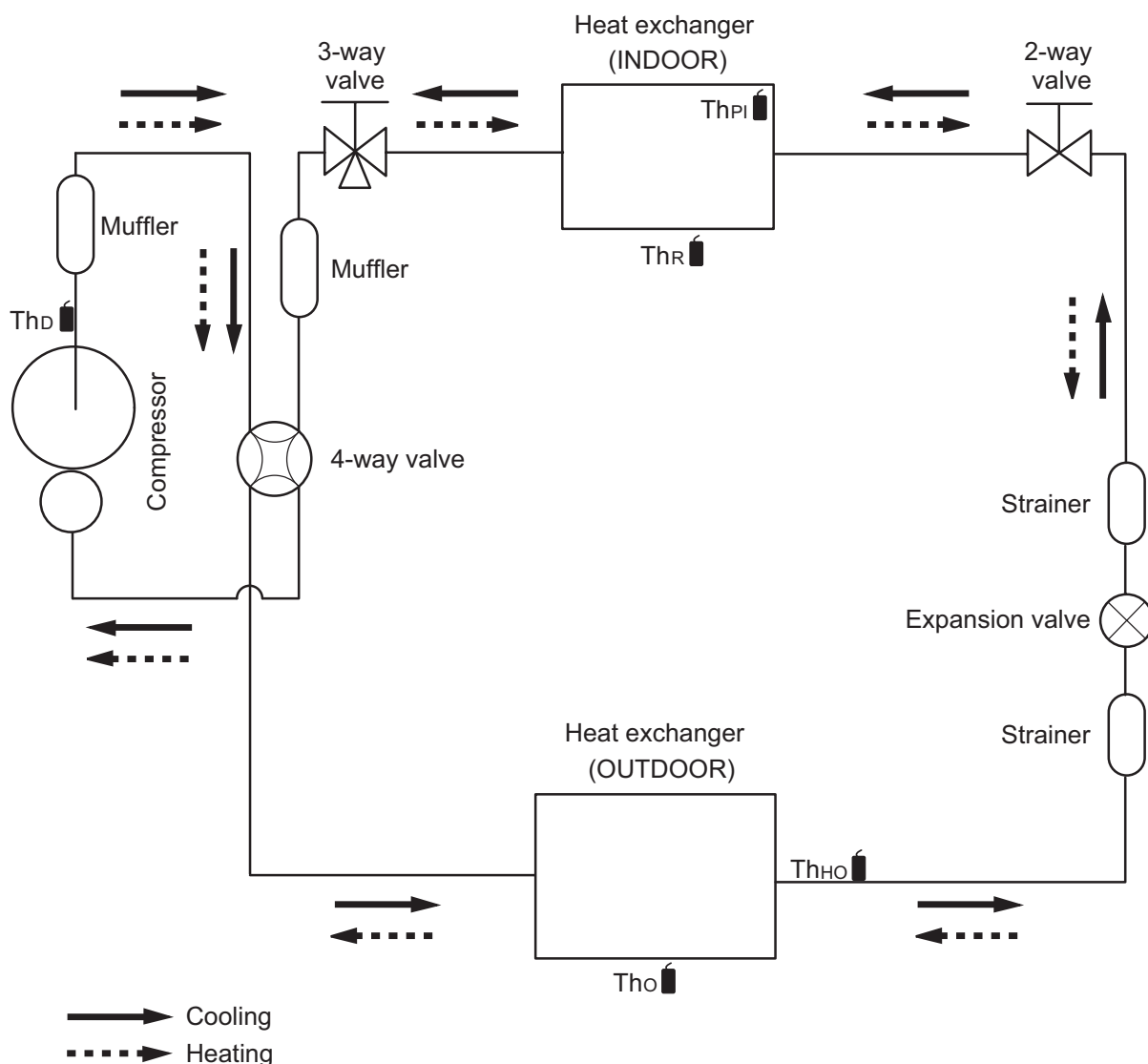

- Th_D : Thermistor (Discharge temperature)
- Th_O : Thermistor (Outdoor temperature)
- Th_{HO} : Thermistor (Heat exchanger out temperature)
- Th_{PI} : Thermistor (Pipe temperature)
- Th_R : Thermistor (Room temperature)

4-2. Model: AOEG24KLCA

OUTDOOR UNIT
AOEG18-24KLCA

OUTDOOR UNIT
AOEG18-24KLCA

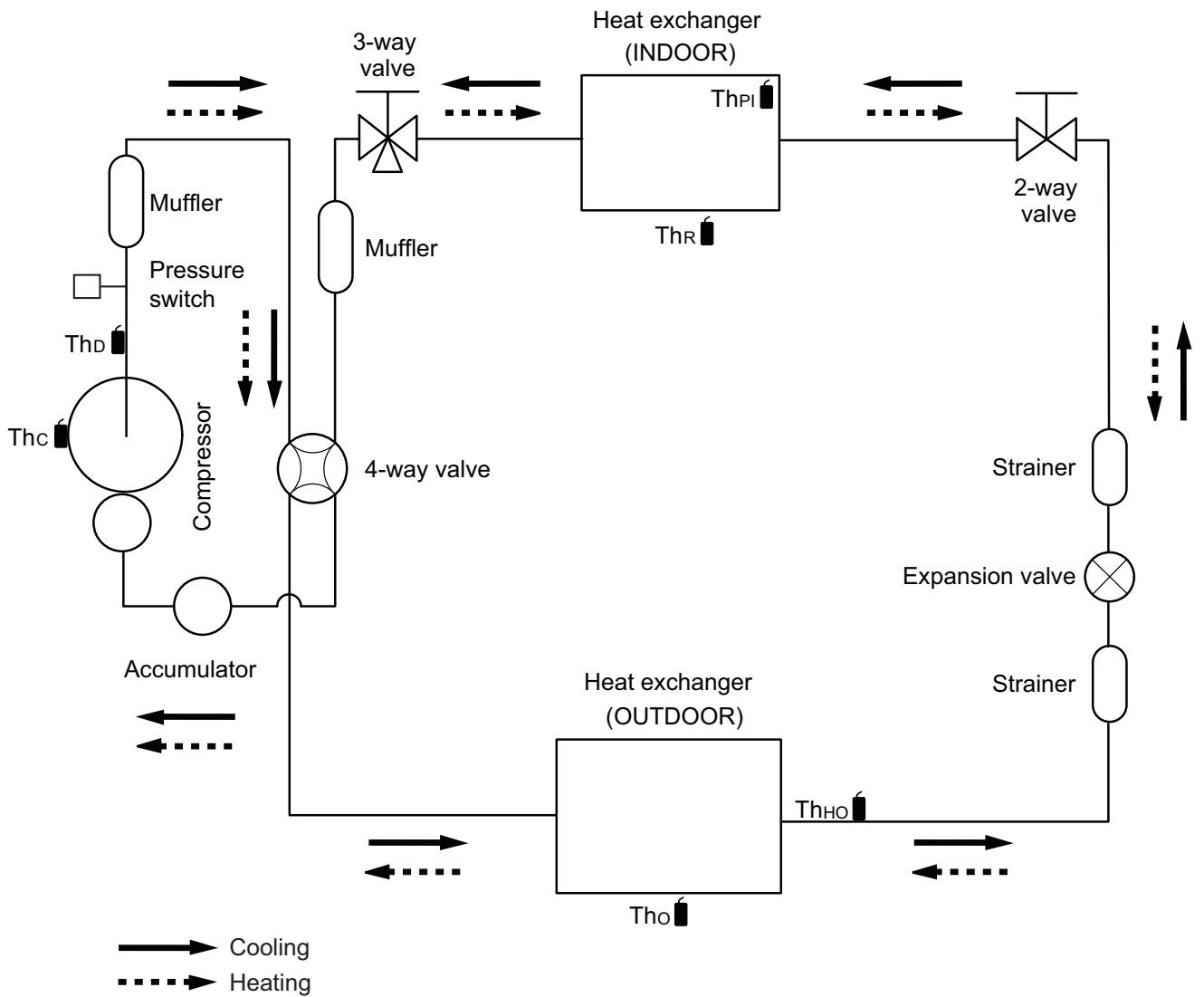

- Thc : Thermistor (Compressor temperature)
- Thd : Thermistor (Discharge temperature)
- Tho : Thermistor (Outdoor temperature)
- Thho : Thermistor (Heat exchanger out temperature)
- ThR : Thermistor (Room temperature)
- ThPI : Thermistor (Pipe temperature)

5. Wiring diagrams

5-1. Model: AOEG18KLCA

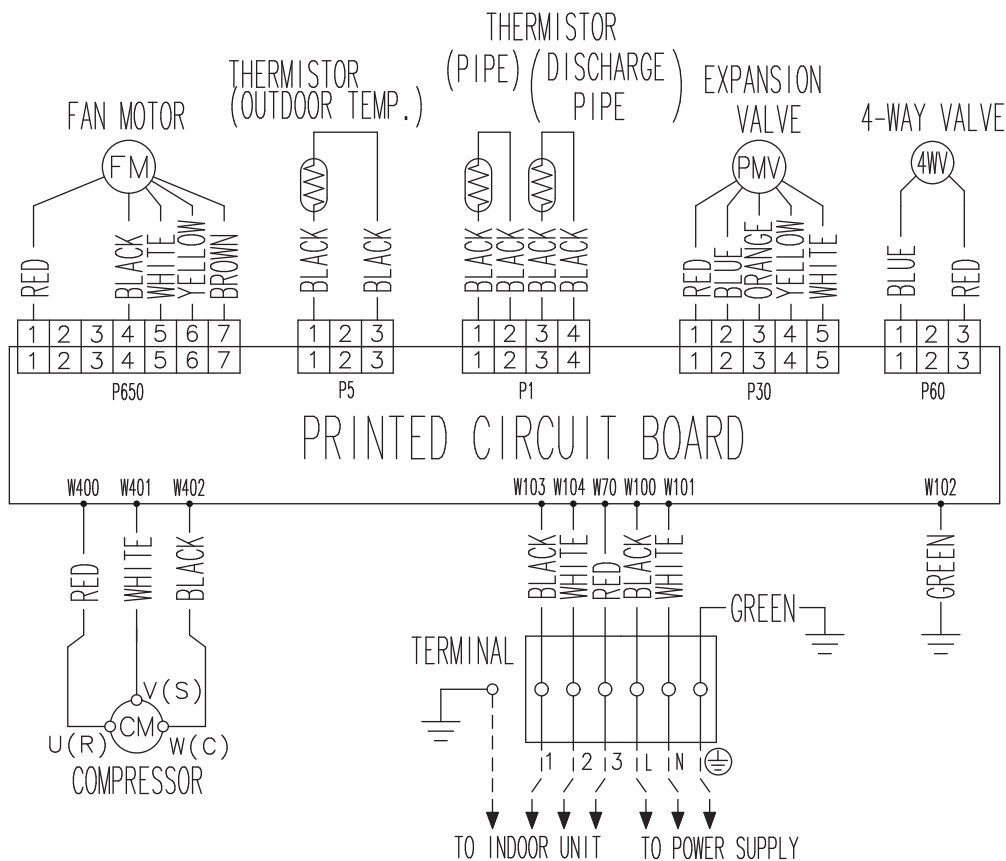

5-2. Model: AOEG24KLCA

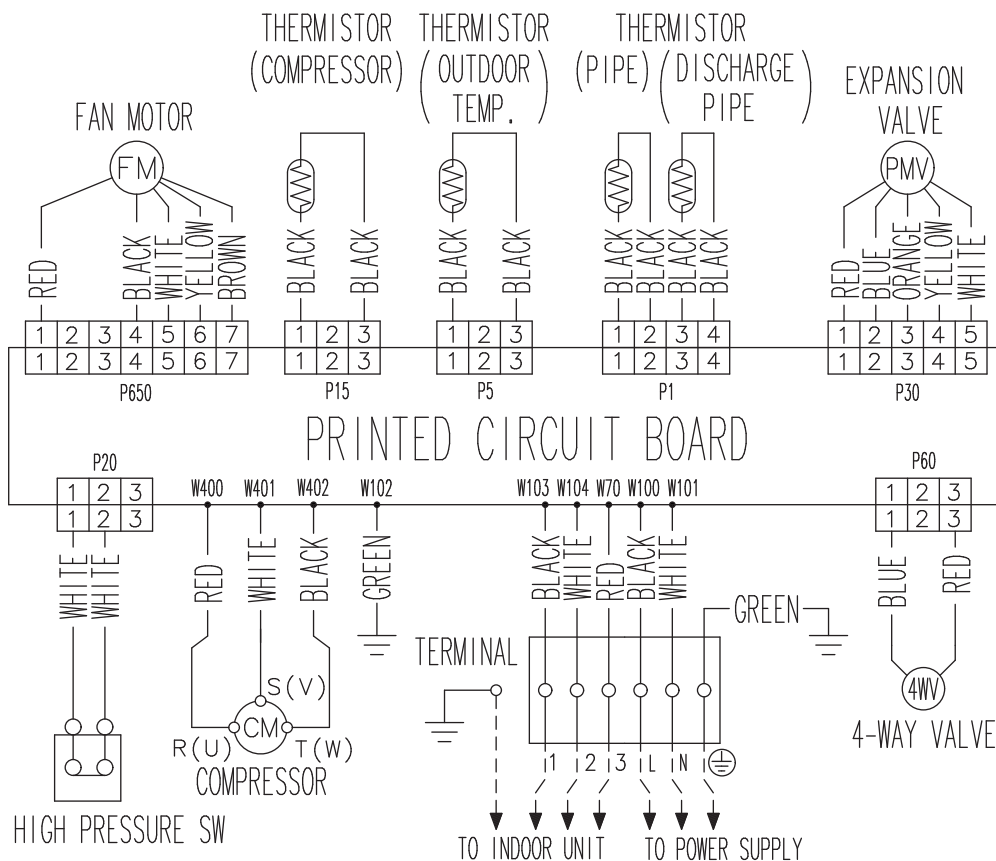

OUTDOOR UNIT
AOEG18-24KLCA

OUTDOOR UNIT
AOEG18-24KLCA

6. Capacity compensation rate for pipe length and height difference

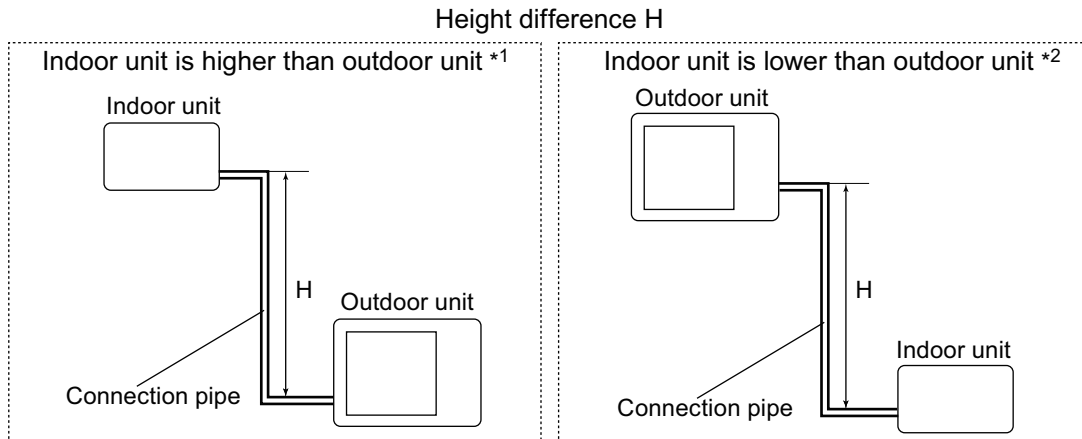

6-1. Model: AOEG18KLCA

NOTE: Values mentioned in the table are calculated based on the maximum capacity.

COOLING			Pipe length (m)					
			5	7.5	10	15	20	25
Height difference H (m)	Indoor unit is higher than outdoor unit *1	20	—	—	—	—	0.872	0.848
		15	—	—	—	0.904	0.879	0.854
		10	—	—	0.951	0.919	0.893	0.868
		7.5	—	0.972	0.955	0.923	0.897	0.872
		5	0.992	0.975	0.959	0.925	0.901	0.876
	Indoor unit is lower than outdoor unit *2	0	1.000	0.983	0.967	0.933	0.908	0.883
		-5	1.000	0.983	0.967	0.933	0.908	0.883
		-7.5	—	0.983	0.967	0.933	0.908	0.883
		-10	—	—	0.967	0.933	0.908	0.883
		-15	—	—	—	0.933	0.908	0.883
-20	—	—	—	—	0.908	0.883		

HEATING			Pipe length (m)					
			5	7.5	10	15	20	25
Height difference H (m)	Indoor unit is higher than outdoor unit *1	20	—	—	—	—	0.863	0.857
		15	—	—	—	0.869	0.863	0.857
		10	—	—	0.934	0.869	0.863	0.857
		7.5	—	0.967	0.934	0.869	0.863	0.857
		5	1.000	0.967	0.934	0.869	0.863	0.857
	Indoor unit is lower than outdoor unit *2	0	1.000	0.967	0.934	0.869	0.863	0.857
		-5	0.995	0.962	0.930	0.864	0.859	0.853
		-7.5	—	0.960	0.928	0.862	0.856	0.850
		-10	—	—	0.926	0.860	0.854	0.848
		-15	—	—	—	0.852	0.846	0.840
-20	—	—	—	—	0.842	0.836		

6-2. Model: AOEG24KLCA

NOTE: Values mentioned in the table are calculated based on the maximum capacity.

COOLING			Pipe length (m)						
			5	7.5	10	15	20	25	30
Height difference H (m)	Indoor unit is higher than outdoor unit *1	25	—	—	—	—	—	0.893	0.877
		20	—	—	—	—	0.917	0.900	0.885
		10	—	—	0.966	0.947	0.932	0.914	0.899
		7.5	—	0.979	0.970	0.951	0.936	0.918	0.903
		5	0.992	0.983	0.974	0.955	0.939	0.922	0.906
	Indoor unit is lower than outdoor unit *2	0	1.000	0.991	0.981	0.963	0.946	0.930	0.914
		-5	1.000	0.991	0.981	0.963	0.946	0.930	0.914
		-7.5	—	0.991	0.981	0.963	0.946	0.930	0.914
		-10	—	—	0.981	0.963	0.946	0.930	0.914
		-20	—	—	—	—	0.946	0.930	0.914
		-25	—	—	—	—	0.930	0.914	

HEATING			Pipe length (m)						
			5	7.5	10	15	20	25	30
Height difference H (m)	Indoor unit is higher than outdoor unit *1	25	—	—	—	—	—	0.871	0.855
		20	—	—	—	—	0.887	0.871	0.855
		10	—	—	0.952	0.903	0.887	0.871	0.855
		7.5	—	0.976	0.952	0.903	0.887	0.871	0.855
		5	1.000	0.976	0.952	0.903	0.887	0.871	0.855
	Indoor unit is lower than outdoor unit *2	0	1.000	0.976	0.952	0.903	0.887	0.871	0.855
		-5	0.995	0.971	0.947	0.899	0.883	0.866	0.850
		-7.5	—	0.969	0.945	0.897	0.881	0.865	0.849
		-10	—	—	0.942	0.894	0.879	0.863	0.847
		-20	—	—	—	—	0.869	0.854	0.838
		-25	—	—	—	—	0.850	0.834	

7. Additional charge calculation

7-1. Model: AOEG18KLCA

Refrigerant type		R32
Refrigerant amount	g	850

■ Refrigerant charge

Total pipe length	m	15 or less	20	25 (Max.)	20 g/m
Additional charge	g	0	100	200	

7-2. Model: AOEG24KLCA

Refrigerant type		R32
Refrigerant amount	g	1,100

■ Refrigerant charge

Total pipe length	m	15 or less	20	25	30 (Max.)	20 g/m
Additional charge	g	0	100	200	300	

8. Airflow

8-1. Model: AOEG18KLCA

● Cooling

m ³ /h	1,830
l/s	508
CFM	1,077

● Heating

m ³ /h	2,265
l/s	629
CFM	1,333

8-2. Model: AOEG24KLCA

● Cooling

m ³ /h	2,885
l/s	801
CFM	1,698

● Heating

m ³ /h	3,030
l/s	842
CFM	1,783

9. Operation noise (sound pressure)

9-1. Noise level curve

Model: AOEG18KLCA

Cooling

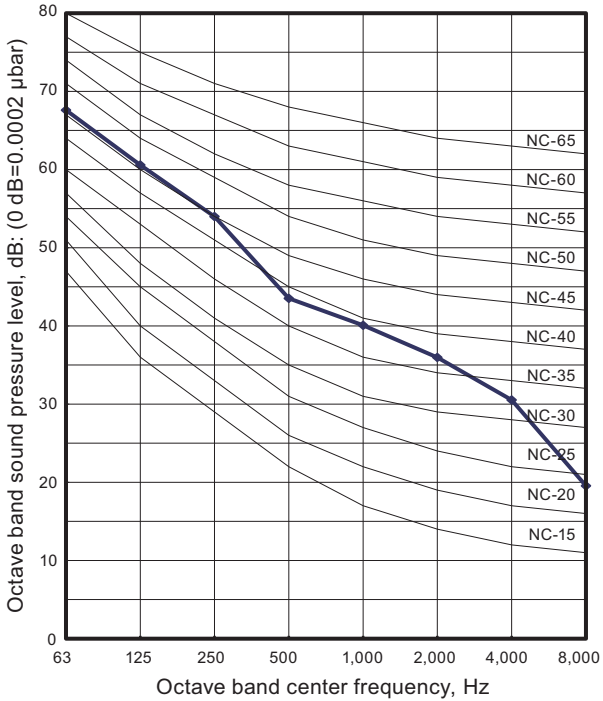

Heating

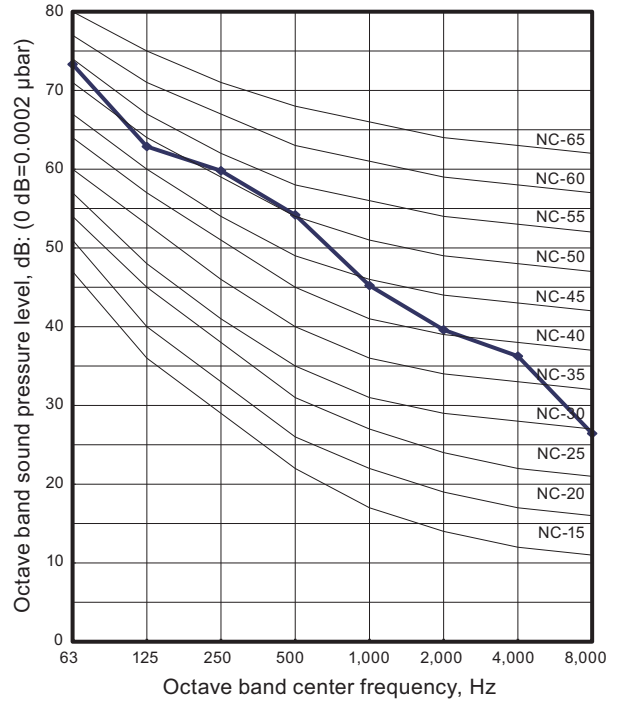

Model: AOEG24KLCA

Cooling

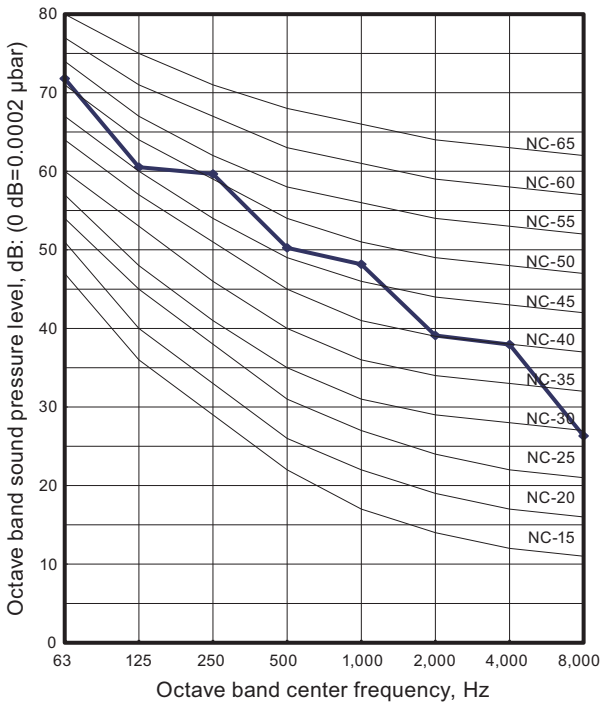

Heating

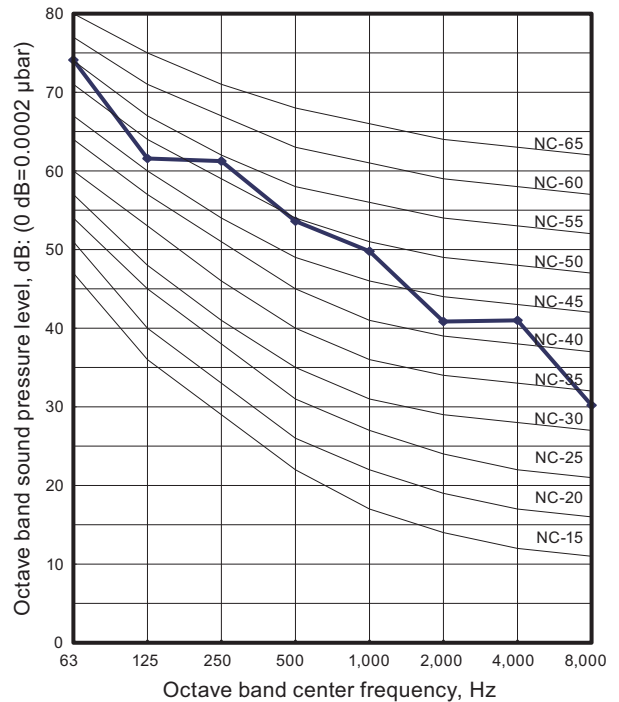

OUTDOOR UNIT
AOEG18-24KLCA

OUTDOOR UNIT
AOEG18-24KLCA

9-2. Sound level check point

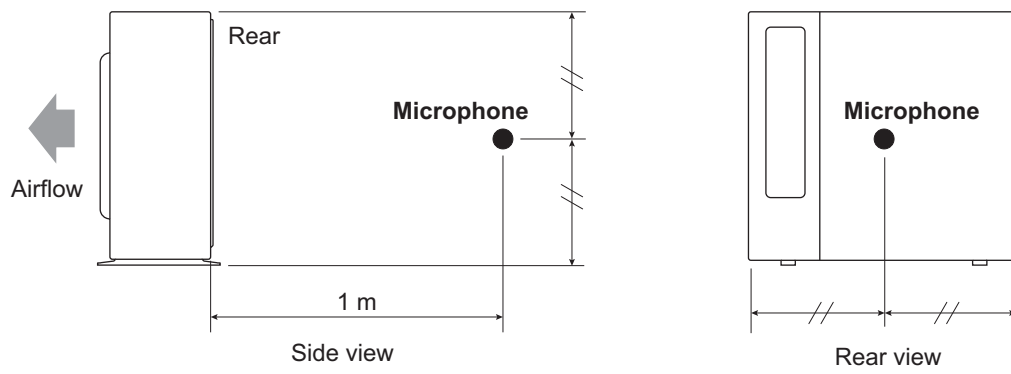

NOTE: Detailed shape of the actual outdoor unit might be slightly different from the one illustrated above.

10. Electrical characteristics

Model name			AOEG18KLCA	AOEG24KLCA	
Power supply	Voltage	V	230 ~		
	Frequency	Hz	50		
Max operating current *1		A	13.5	17.5	
Starting current		A	8.0	10.9	
Wiring spec. *2	Circuit breaker current		A	15	20
	Power cable		mm ²	1.5	
	Connection cable *3	Cross-sectional area	mm ²	1.5	
		Limited wiring length	m	26	31

*1: Maximum operating current is the total current of the indoor unit and the outdoor unit.

*2: Selected sample based on Japan Electrotechnical Standards and Codes Committee E0005. As the regulations of wire size and circuit breaker differ in each country or region, select appropriate devices complied to the regional standard.



*3: Limit voltage drop to less than 2%. If voltage drop is 2% or more, increase cable conductor size.

11. Safety devices

Type of protection	Protection form	Model	
		AOEG18KLCA	AOEG24KLCA
Circuit protection	Current fuse (Main PCB)	250 V, 20 A	250 V, 25 A
		250 V, 5 A	
		—	250 V, 3.15 A
Fan motor protection	Terminal protection program	Activate	100±15 °C Fan motor stop
		Reset	125±10 °C Fan motor stop
Compressor protection	Terminal protection program (Discharge temp.)	Activate	95±10 °C Fan motor restart
		Reset	120±10 °C Fan motor restart
Compressor protection	Terminal protection program (Discharge temp.)	Activate	110 °C Compressor stop
		Reset	115 °C Compressor stop
			After 7 minutes Compressor restart
			After 3 minutes Compressor restart

12. Accessories

12-1. Models: AOEG18KLCA and AOEG24KLCA

Part name	Exterior	Q'ty	Part name	Exterior	Q'ty
Installation manual		1	Drain pipe		1